

Copyright  
by  
Jean Kathleen Krejca  
2005

**The Dissertation Committee for Jean Kathleen Krejca Certifies that  
this is the approved version of the following dissertation:**

**Stygobite phylogenetics as a tool for determining aquifer  
evolution**

**Committee:**

---

David M. Hillis, Supervisor

---

Dean Hendrickson, Co-Supervisor

---

Ulrich G. Mueller

---

John M. Sharp, Jr.

---

George Veni

**Stygobite phylogenetics as a tool for determining aquifer  
evolution**

**by**

**Jean Kathleen Krejca, B.S.**

**Dissertation**

Presented to the Faculty of the Graduate School of

The University of Texas at Austin

in Partial Fulfillment

of the Requirements

for the Degree of

**Doctor of Philosophy**

**The University of Texas at Austin**

**May, 2005**

## **Dedication**

This work is dedicated to the most adventurous woman I know, my caving partner and wife, Vivian I. Loftin.

## **Acknowledgements**

This work could not have been accomplished without the unending help of many different people. First, my parents for providing an environment that allowed me to pursue a path of my own design. My committee provided advice and comments on the manuscript, and particularly to Dave Hillis, Dean Hendrickson and George Veni for their unending help with navigating the steep topography of graduate school, finding caves to sample, and going out with me to do field work. Everyone in the Dave Hillis and Jim Bull labs helped me with learning DNA work, from extraction to sequencing, and particularly to Derrick Zwickl for his help with phylogenetic analysis. Tracy Heath and Shannon Hedtke were also there for me in the last round of working through the analysis. The Texas Speleological Survey and all of the volunteers there helped by providing me with cave location and landowner information. Patrick Connor at the U.S. Fish and Wildlife Service provided important help with GIS distance matrix functions, and others at USFWS gave moral support both during and after my tenure there. Travis LeDuc provided me with

maps, Malia Ana Rivera and Frank Howarth helped with CO1 primers, Radu Boghici and Sylvia Pope provided literature on border hydrology.

I am also indebted to all of the landowners that granted me permission to access these sites and sample there, and to all of the land managers that assisted with logistics of access and sampling. These people include: Homero Amezcua, David Baker, Carlos Botello, Roger Biggers, Tom Brown, Marco Antonio Cardozo M., DeeAnn Chamberlain, Sam Dandridge, Michelle and Sean Devaney, José Falcón, Salvador Martinez Garza, Darrell Hargrove, Jay Hess, Deirdre Hisler, John Hoyt, James and Betty Klar, Dave Larson, Glenn Longley, Clark Lytle, Hugo Martinez, Wayne Mathis, Robert McCurdy, AnnMarie Mikelski, Tom Morris, Buddy Mostyn, MaryLynn Musgrove, Linda Palit, José H. Múzquiz Quedea, Terry de la Rosa, Randy Rosales, Guillermo Osuna Saenz, Geary Schindel, Lewis Tyra, Javier Valdez, Ross Whitten, P. Wiley. The places that granted me permission and helped with logistics include: Amistad National Recreation Area, Brackenridge Zoo, Bureau of Reclamation, City of Austin, Colorado Bend State Park, Edwards Aquifer Authority, Government Canyon State Natural Area, Guadalupe River State Park, Junta Administradora de Agua Potable y Alcantarillado de Múzquiz Coahuila, Longhorn Caverns, Lost Maples State Park, Lower Colorado River Authority, New Braunfels Utilities, Pedernales Falls State Park, Texas State University, Wonder World Park.

The following cavers and biologists helped me find and access collecting localities: Jerry Atkinson, Roger Bartholemew, Paul Chippindale, Jon Cradit, Randy Gibson, Andy Grubbs, Bob Hershler, John Holsinger, Terry Holsinger, James Loftin, Glenn Longley, Scott Harden, Robert Herschler, John Holsinger, Jim Kennedy, Dale Pate, James Reddell, William Russell and Peter Sprouse.

Field work for this project was extensive, spanning many years and a multitude of small, wet, muddy, vertical and sometimes uncomfortable places. I am indebted to the following people for their help with that: Nathan Allan, Melanie Alspaugh, Kaye Barlow, Aimee Beveridge, Don Broussard, Chris Buntentah, Terry Burgen, Giorgio Carramana, Jorge Homero Rodríguez Castro, DeeAnn Chamberlain, Allan Cobb, Adam Cohen, James Cokendolpher, Salvador Contreras-Balderas, John Cradit, Don Dearborn, Brett Dodson, Gary Dunkley, Earthwatch Team 2001 and 2002, Fernando Vanage Eligio, Robert Escaline, Digger Feakes, Marcus Gary, Robin Gary, Steve Gerrard, Andy Gluesenkamp, Alan Goodman, Andy Grubbs, Aldo Antonio Guevara Carrizales, Tom Haile, Sue Hanna, Greg Hanson, Scott Harden, Dean Hendrickson, Garrett Hendrickson, Jacob Hendrickson, Dave Hillis, Goeff Hoese, Terry Holsinger, Jody Horton, Whitney Howeth, Pete Hurd, Tom Iliffe, Joe Ivy, Chrissy Jett, Yara Sanchez Johnson, Becky Jones, Jan Klein, Chris Krejca, Mike Lang, Bill Larson, Dave Larson, Celene Denev Acuna Leal, Cindy Lee, Ted Lee, Francisco Garcia de Leon, Mike Loeffler, Llyn Loftin, Vivian Loftin, James

Lopez, Joyce Luck, Carol Malcom, Jane Marks, Tania Yssel Flores Martinez, Robert McCurdy, R.D. Millholin, John Mitchell, Mike Moore, Jaime Moreno, Collin Morris, Tom Morris, John Moseley, Jen Mui, Rae Nadler-Olenick, Walt Olenick, Kane Overfield, Hector Espinosa Perez, Chris Philips, Sammy Pizzo, Mary Poteet, Denise Prendergast, Julie Rhodes, Jason Richards, William Russell, Azael Salazar, Mark Sanders, Charley Savvas, Bill Sawyer, Greg Sedbrook, Kathy Scanlon, Geary Schindel, Travis Scott, Pete Shifflett, Peter Sprouse, Lara Storm, Dave Stuart, David Sweetin, Pam Tanino, Steve Taylor, Emily Thompson, Bruce Tipps, Jody Trainey, Bill Tucker, Anastasio Urbina, George Veni, Chris Vreeland, Erin Vreeland, Felicia Vreeland, Kate Walker, Mike Warton, Cindy Warton, Faith Watkins, Andrew Wyatrick.

I have been lucky to work with several karst consultants during my studies, and I'm grateful to them for their support of my dissertation work, their help with placing it in the context of local conservation problems, and their guidance for my career path: George Veni and Associates, James Reddell, Peter Sprouse and Zara Environmental LLC.

Finally, a critical part of the success of this project was direct funding that came from the following sources: P.E.O. Presidential endowed Scholar award, UT Environmental Studies Institute Graduate Fellowship, Ralph Stone Award of the National Speleological Society, UT Continuing Tuition Fellowship, North American Native Fishes Association research award, Sigma Xi Grants in Aid, National Speleological Society



Research Advisory Council, Karst Research Grant from Cave Research Foundation, UT Institute for Latin American Studies Tinker fellowship, UT Zoology Departmental fellowship, Phi Kappa Phi.

# **Stygobite phylogenetics as a tool for determining aquifer evolution**

Publication No. \_\_\_\_\_

Jean Kathleen Krejca, PhD

The University of Texas at Austin, 2005

Supervisors: David Hillis and Dean Hendrickson

Abstract: The use of aquifer-dwelling organisms (stygobites) for learning about past and present subterranean hydrologic connections was evaluated in the Edwards (Balcones Fault Zone), Trinity, and Edwards-Trinity (Plateau) aquifers of Texas and adjacent areas in north Mexico, an area with complex karst groundwater flow and sociopolitical problems stemming from overuse and contamination. *A priori* predictions of subterranean hydrogeologic history were made based on a literature review, and these predictions were compared to phylogenies of two aquifer dwelling isopods created based on mitochondrial gene sequences (16S ribosomal RNA and cytochrome c oxidase subunit I). Using likelihood and parsimony-based comparisons, *Cirolanides* (Isopoda:

Cirolanidae) was found to have a phylogenetic history congruent with *a priori* predictions of subterranean hydrogeologic history in its terminal nodes. Conversely, basal branches of the phylogenetic tree had placement that was not predicted by this history, a phenomenon that may be indicative of a lack of understanding of subterranean hydrogeology of the area. *Lirceolus* (Isopoda: Asellidae) had a phylogenetic history congruent with an alternative hypothesis of water flow, namely the patterns of surface drainages. This difference of patterns for two species that both live in the aquifer is probably related to their ecology and evolutionary history, with *Cirolanides* having invaded the cave habitat as a single marine population and *Lirceolus* invading the cave habitat as a freshwater migrant with possible pre-existing genetic structure determined by surface drainages. This study pioneers testing of *a priori* biogeographic hypotheses using phylogenies of aquifer organisms and the creation of hydrogeologic histories in a karst setting, and supports the use of these methods to aid in understanding biogeography and aquifer evolution.

## Table of Contents

List of Tables .....	xiv
List of Figures.....	xv
List of Figures.....	xv
Introduction .....	1
Materials and Methods .....	5
Study Area .....	5
Taxon Sampling .....	7
Abiotic Hypotheses: Subterranean Hydrogeology .....	10
Abiotic Hypotheses: Surface Rivers .....	12
Abiotic Hypotheses: Distance Matrix .....	13
DNA Methods .....	13
Phylogenetic Analyses .....	15
Testing Abiotic Hypotheses .....	16
Results .....	19
Abiotic Hypotheses.....	19
Subterranean Hydrogeology .....	19
Surface Rivers.....	29
Distance Matrix .....	31
Gene Trees .....	34
Tree comparison .....	39
Discussion .....	46
Subterranean Hydrology .....	46
Surface Rivers.....	48
Distance Matrix.....	49

Taxon Congruence.....	51
Parametric Bootstrapping.....	52
The Rio Grande as a Barrier: Is Mexico Part of the Edwards- Trinity Aquifer? .....	62
Comparison to Relationships of Other Aquatic Taxa.....	64
Conservation Implications .....	66
Appendix I .....	69
Appendix II .....	74
Bibliography .....	89
Vita.....	99

## List of Tables

Table 1. Results of comparison between gene trees and abiotic trees using maximum likelihood ranks and the TreeMap randomization test. ....	43
Table 2. Summary of constraint trees including results of parametric bootstrapping.....	45

## List of Figures

Fig. 1. Map of isopod localities .....	6
Fig. 2. Abiotic tree showing relationships between <i>Cirolanides</i> populations based on subterranean hydrogeology.....	20
Fig. 3. Abiotic tree showing relationships between <i>Lirceolus</i> populations based on subterranean hydrogeology.....	26
Fig. 4. The river tree for <i>Cirolanides</i> collecting localities .....	30
Fig. 5. The river tree for <i>Lirceolus</i> collecting localities. ....	31
Fig. 6. Distance matrix tree showing relationships of sites where <i>Cirolanides</i> were collected .....	32
Fig. 7. Distance matrix tree showing relationships of sites where <i>Lirceolus</i> were collected .....	33
Fig. 8. <i>Cirolanides</i> gene tree based on the criterion of maximum likelihood .....	36
Fig. 9. <i>Cirolanides</i> gene tree based on the criterion of maximum likelihood, showing non-parametric bootstrap values and Bayesian posterior probabilities .....	37
Fig. 10. <i>Lirceolus</i> gene tree based on the criterion of maximum likelihood. ....	38
Fig. 11. Comparison of <i>Cirolanides</i> gene tree and subterranean hydrogeology tree .....	40
Fig. 12. Comparison of <i>Lirceolus</i> gene tree and subterranean hydrogeology tree. ....	41

Fig. 13. Comparison of <i>Lirceolus</i> gene tree and surface river tree .....	42
Fig. 14. Map showing genetic relationships of <i>Cirolanides</i> localities .....	53
Fig. 15. Map showing genetic relationships of <i>Lirceolus</i> localities.....	60



## **Introduction**

Central Texas karst aquifers, including the Edwards (Balcones Fault Zone), Trinity, and Edwards-Trinity (Plateau) aquifers, and adjacent areas in north Mexico, span a very large geographic area and include the Edwards Aquifer, which is one of the most productive aquifers in the southwestern United States, and is one of the most biodiverse of any aquifer in the world (Longley 1981; Reddell 1994). Conflicts with these aquifers are many, including endangered species, contamination, and overuse by an expanding human population that has resulted in accelerated rates of spring drying and species extinctions (Brune 1981). Central to coordinating use of aquifers by different interests is a detailed understanding of regional subterranean flowpaths. Hydrogeologists use various methods to map these flowpaths to determine flowpaths, but detailed studies are inconsistently available (Sharp and Banner 1997), and most methods focus on current groundwater flowpaths, even though an understanding of the evolution of the hydrogeologic system is an invaluable tool for interpreting the current setting.

This study proposes use of evolutionary patterns of groundwater-obligate species (stygobites) to aid in interpreting the hydrogeologic setting of the central Texas karst aquifers and adjacent aquifers of north Mexico. Just as biological populations change by expanding their range, hybridizing or speciating, aquifer systems change through time. They can

be drained by freshly exposed springs, partitioned by surface erosion of the host rock, or can join an adjacent system via piracy. In a karst setting, typified by sinkholes, subterranean water-filled conduits, springs and caves, historic groundwater flowpaths can play a significant role in understanding modern hydrologic connections because those flowpaths may still be used during high flow events, directing water (and therefore fauna, contaminants, etc.) across what are, during normal aquifer levels, drainage divides. These historic connections and high-flow routes can be difficult to detect during standard hydrogeologic examinations that include techniques such as potentiometric surface mapping, dye tracing, and karst feature mapping. It seems likely that the genetic history of stygobites, organisms restricted to living in the groundwater, could be a valuable tool to add to the standard hydrogeologic methods toolbox. The Edwards Aquifer in particular provides an excellent testing ground for this tool because in many areas the patterns of surface water flow and groundwater flow are strikingly different, with surface water typically flowing southeast, and groundwater flowing northeast.

Many studies of genetics of cavernicoles (cave-dwellers) discuss hydrologic connectivity or geologic vicariance events, but typically only in a casual sense, and limited to an a posteriori interpretation to explain the distribution of genetic diversity of species and populations (Ketmaier et al. 1998; Kane et al. 1992; Espinasa and Borowsky 2001; Berettoni et al. 1998; Baratti et al. 1999; Mathieu et al. 1997). Other authors use geologic

history to test hypotheses related to the mode of cave invasion and to forces generating troglomorphy (physical cave adaptations such as eyelessness) (Avice and Selander 1972; Culver et al. 1995; Kane et al. 1992; Leys et al. 2003). Only one study explicitly tested concordance of genetic distances (measured by allozyme electrophoresis), drainage basins, and morphology (Culver et al. 1995), finding that genetics and hydrology had high concordance while genetics and species morphology had low concordance. Although the present study is similar in asking whether genetic similarity is bound by hydrologic connectivity, Culver et al. (1995) were less extensive because they used a limited number of genetic characters (13 enzyme systems encoded by 18 presumptive loci), a simple clustering method for creating gene trees (UPGMA), and a test statistic lacking significance values.

Though many studies in cladistic biogeography use geologic history to explain the interaction of organisms with the areas that they inhabit, geologic history is typically secondarily examined in an effort to explain cladogenetic events (e.g. Hidding et al. (2003). A truly multi-disciplinary approach would create an *a priori* geologic hypothesis that encompasses the study area, then compare the geologic hypothesis to an independently derived biological tree for taxa that occur in that range. At least one study pointed out the need to create such independent, *a priori* area cladograms based on specific analyses of geological characters in the same way characters are analyzed in systematics (Morrone and Crisci, 1995), and

others have tended toward this approach by using a wealth of geologic information in their discussion (Hendrickson 1986). However, there have been no studies comparing a detailed *a priori* hydrogeologic hypothesis with a biological one, essentially testing the congruence of biological cladograms and cladograms of geological history.

This study creates a comprehensive *a priori* hydrogeologic history of central Texas karst aquifers and translates it into a branching tree. Two alternative abiotic trees are also created based on the relationships of surface rivers and geographic distances between sites. Next, two groups of stygobitic isopods are sampled across the aquifers and phylogenetic trees are created for each one using mitochondrial DNA sequencing. These biological trees are compared against the three abiotic trees. The comparison is performed on each of the entire trees using a likelihood based approach, a parsimony based approach, and an analysis of specific clades of the trees is done using parametric bootstrapping. Given a matching pattern to groundwater flow, the phylogenetic relationships of stygobites may aid in understanding and managing this complex aquifer system.

## **Materials and Methods**

### **STUDY AREA**

The study area mapped in Figure 1 covers several different karst aquifers in Texas and some adjacent groundwater basins in northern Mexico. Aquifers are named after the rock formation they occur in, and the nomenclature and mapping for Texas is fairly detailed compared to what is available in Mexico. Because the study area covers multiple aquifers with similar names, during general discussions the terminology “central Texas karst aquifers” will be used. Specifically, this term includes the following: 1) Edwards (Balcones Fault Zone) Aquifer, which includes the San Antonio, Barton Springs, Northern and Washita Prairie segments, 2) Edwards-Trinity (Plateau) Aquifer, (not the Edwards-Trinity High Plains Aquifer), 3) parts of the Trinity Aquifer yielding water from the Glen Rose Formation and Cow Creek Limestone (Ashworth and Hopkins 1995), 4) a single site in the Ellenberger Group, and 5) a single site (Isopit) in the Austin Chalk formation in Bexar County (see Figure 1). Adjacent karst aquifers in the north Mexican states of Coahuila and Nuevo Leon are also included in the study.

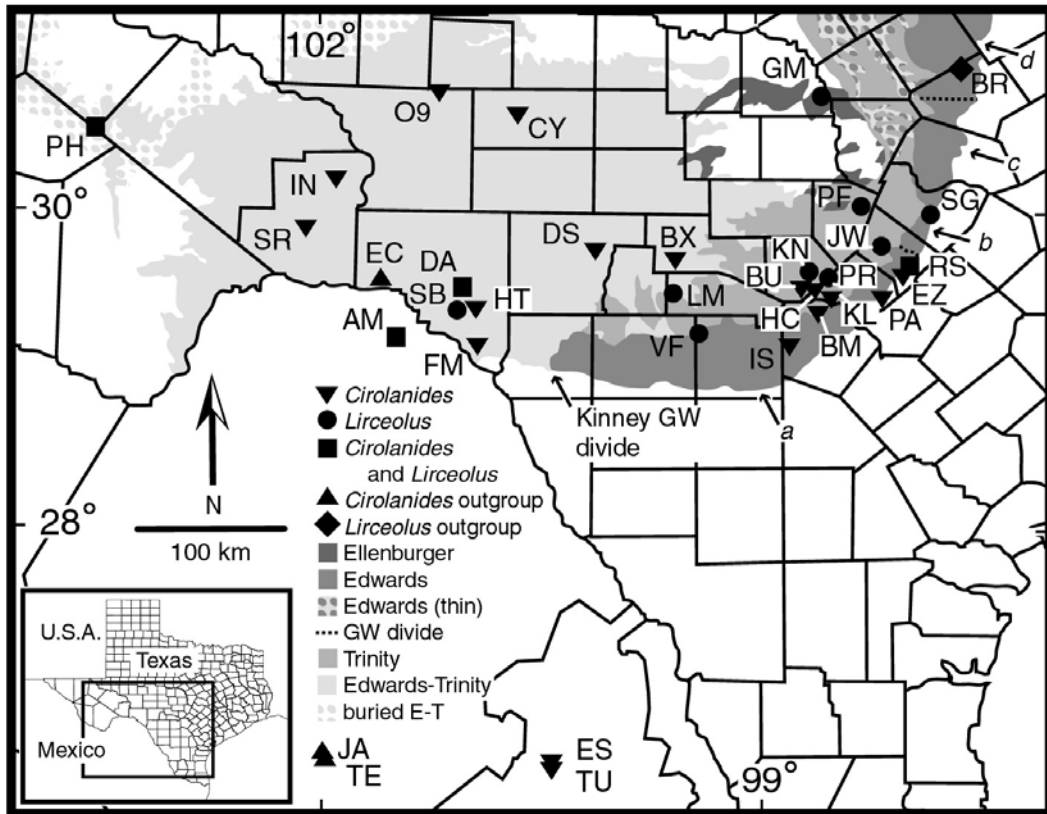

Fig. 1. Map of isopod localities. Icons indicate what taxa were collected, two letter site codes correspond to locality names in Appendix I, and shaded areas show aquifers and geologic units. One site, OE, is not shown on the map but is located in west central Tamaulipas, Mexico. The boundaries of the Ellenburger Group consist of exposed portions of Tanyard, Gorman and Honeycut Formations. The Edwards Aquifer boundaries represent both exposed and downdip buried strata in the Balcones Fault Zone. Dotted lines within the Edwards mark drainage divides: a = San Antonio Segment, b = Barton Springs Segment, c = Northern Segment, d = Washita Prairie Segment (generalized to include the Walnut formation). To the west of the Northern Segment and Washita Prairie Segment, fingers of Edwards limestone are hatched with a darker shade to indicate they are contiguous but thin and hydrologically distinct from the rest of the Edwards. The Trinity and Edwards-Trinity boundaries represent only exposed strata. Buried sections of the Edwards-Trinity in the northwest corner of the map are hatched to show subterranean continuity between sites.

Cretaceous deposition (approximately 144 to 65 mya) across vast areas of Texas provided the large, continuous areas of limestone where the species discussed herein now occur. The Edwards Limestone Group is subdivided into several units which will be collectively referred to as Edwards Limestone. Balcones faulting (approximately 20 to 12 mya) separated the Balcones Fault Zone section of the Edwards Limestone from the Edwards Plateau section along most of their boundaries, delimiting the Edwards Aquifer and the Edwards-Trinity Aquifer.

The Laramide orogeny (approximately 60 mya) to the west and Balcones faulting provided new topographical relief to streams running across Texas, causing them to cut through sediments deposited above the Edwards Limestone, exposing it for cave development. Though some cave development occurred during one exposure of the Edwards Limestone during the Late Cretaceous (Washitan time, end of Comanchean), most cave development occurred after Balcones faulting that provided the relief necessary for downcutting of riverbeds, drainage of phreatic (=water filled) voids, and subsequent establishment of underground drainage pathways (Woodruff and Abbott 1986; Barker and Ardis 1996).

#### **TAXON SAMPLING**

The two isopod genera, *Cirolanides* and *Lirceolus*, in the families Cirolanidae and Asellidae, respectively, were chosen because of their strictly subterranean distribution across central Texas karst aquifers and

into northern Mexico, where the rock is geologically equivalent but presumably hydrologically separate from central Texas. There are two other isopod genera with approximately this same distribution, *Mexistenasellus* (Stenasellidae) and *Speocirolana* (Cirolanidae), and these were also collected, but they were relatively rare and were omitted from the tree comparison analyses since the paucity of collecting localities made comparisons among drainage basins meaningless. Distribution records for the two study genera were obtained from the database of cave invertebrates at the Texas Memorial Museum (University of Texas at Austin), and several new localities were discovered during the course of this study. Collecting localities are mapped in Figure 1, full names for these sites are given in Appendix I, and site descriptions are given in Appendix II.

Outgroups were chosen for the two genera based on a literature review of the families. The genus *Lirceolus* is endemic to Texas and Mexico, and although early studies suggested a basal placement within the Asellidae (Lewis 1988) and a relationship to *Lirceus* (Bowman and Longley 1976), recent work using more morphological characters from more widely sampled taxa place *Caecidotea* as the outgroup to *Lirceolus* (Lewis and Bowman 1996) and this placement is used herein.

The distribution of the freshwater stygobionts of the family Cirolanidae along the ancient marine shoreline leads many authors to suggest that these genera evolved from a marine ancestor (Bowman



1964; Botosaneanu et al. 1998; Cole and Minckley 1966; Cole and Minckley 1970) but phylogenetic relationships within the family are not resolved. One author considers that *Cirolanides* may be closest to *Antrolana*, based on some pereopod characteristics (Bowman 1964). Another study suggests that *Sphaerolana* and *Speocirolana* are in the same family, but relationships between the genera are distant (Cole and Minckley 1970). Although a morphology-based phylogenetic analysis of the family is underway, results are not yet available (Julia Kouwenberg, personal communication). Considering this lack of systematic understanding within the family, outgroup taxa for this study were chosen based on their allopatric distribution and availability, and include *Sphaerolana* from Mexico and *Speocirolana* from Mexico and Texas.

Collecting in caves involved a team with extensive experience in that environment, including technical ropework and cave SCUBA methods, and followed high standards of safety and conservation etiquette (Rea 1987; Padgett and Smith 1987; Prosser and Grey 1992). A combination of capturing methods was used, including turkey baster assisted suction combined with a dipnet, hand picking, and plastic inverted funnel traps left for 24-48 hours or more. In many cases specimens of *Cirolanides* could be found swimming through the water column or traveling over mud and rocks on the bottom of stream pools, and *Lirceolus* were found clinging to the undersides of rocks or walking on woody debris. In some cases traps were left baited with Vienna sausage and weighted

with rocks. These traps were effective at catching *Cirolanides* but never yielded *Lirceolus*, which may be more substrate dependent and less likely to swim through the water column to bait than *Cirolanides*. Sampling while on SCUBA was done by hand using screw top plastic tubes and a turkey baster for suction. Spring sites were sampled by hand picking and by leaving cotton mop heads or 500 micron mesh nets placed over the flow. Well sampling was done using the same mesh nets placed over the flow, or with baited plastic inverted funnel traps lowered into the well casing. Live specimens were placed in a DMSO + NaCl (dimethylsulfoxide and sodium chloride) solution, 95-100% ETOH (ethanol), or liquid nitrogen. When enough specimens were collected, some were also placed in 70% ETOH for morphological work.

#### **ABIOTIC HYPOTHESES: SUBTERRANEAN HYDROGEOLOGY**

Abiotic trees were generated for the *Cirolanides* and *Lirceolus* aquifer sites mapped in Figure 1 using several independent data sets compiled *a priori*. These data sets include: 1. subterranean hydrogeologic connections, 2. surface drainage basins, 3. a geographic distance matrix.

There are no standard methods available to translate the entire hydrogeologic history of an area into a branching tree that represents historical relationships between subterranean drainage basins. In order to develop a procedure, several pieces of geological and hydrological information were used. The abiotic hypotheses were created under the

assumption of a single cave invasion of the aquifer-dwelling taxa, thus a monophyletic history of these populations.

On a local scale, the underground drainage pathways are what determined placement of specific collecting localities in the subterranean hydrogeology tree. Information from karst hydrogeology studies, including cave maps, dye tracing, potentiometric surface mapping, and local geologic setting were used to infer probable relatedness of these within-aquifer sites. Frequently the data are more complete on a local level, near population centers in the eastern part of the study area, and for current hydrogeologic connections. There are more data points in the form of wells and dye traces near cities where contamination or drawdown problems have demanded that thorough studies be done. Very few studies address the evolution of central Texas aquifers (Veni 1994a; Veni 1997b; Woodruff, Jr. and Abbott 1986), although there are many studies that map the modern and recent relationships among sites represented in the terminal nodes of the tree (Hauwert et al. 2002; Maclay and Land 1988; Maclay 1995; Ogden et al. 1986; Stein and Ozuna 1996). For these reasons, many of the local drainage relationships could be determined with greater confidence than could the relationships across the entire state. The uncertainty of deep relationships is reflected by alternative placements of entire clades that result in a total of 16 plausible hydrogeologic tree configurations for *Cirolanides* and 8 for *Lirceolus*, as described in the results section.

## **ABIOTIC HYPOTHESES: SURFACE RIVERS**

Another possibility is that gene flow in subterranean organisms is a function of surface hydrology. Since these organisms are known to occur at spring orifices, they may occasionally be involuntarily flushed out and travel via surface drainages to invade other spring mouths and consequently other subterranean drainage basins. River travel by eyeless crustaceans is not likely during daylight and clear water times because they are quickly eaten by eyed surface predators. Such predation was repeatedly witnessed during collections at spring orifices. However, since flood events often include reduced visibility and stream temperatures in Texas seasonally approximate cave temperatures, it may be possible for dispersal to occur via surface drainages. There are no records of a stygobite caught in a surface stream during a flood event, but there has likely been very little sampling aimed at that interval. Another possibility is that these organisms can travel through the stream alluvium. *Lirceolus* are known from a single alluvial location, but attempts to collect during this study produced no more specimens for analysis. In review, this phenomenon of surface dispersal has not been observed in the literature or during this study.

Surface river trees were created for the sample locations simply using the relationships of the surface drainage basins in which each site occurs. When three or more caves occurred in a single basin, and relationships between the sites were not clear, a polytomy was invoked.

There was also a basal polytomy assumed where all of the rivers meet the Gulf of Mexico.

#### **ABIOTIC HYPOTHESES: DISTANCE MATRIX**

Another scenario of subterranean connections is that these organisms disperse equally well through any area of the subsurface, and relatedness of populations simply follows geographic proximity. Although geologic evidence does not support the idea that all of the bedrock across the range of this study is equally permeable, it is clearly possible that these tiny crustaceans could follow spaces as small as 2 mm in diameter where the permeability is not well mapped or studied because the majority of subsurface water flows through larger conduits. If this scenario is true, then it is expected that the gene tree will most closely match a tree created using a linear geographic distance matrix.

A distance matrix was created for all sample locations using Geographic Positioning System data collected in the field and the “Distance Matrix of Point Features” extension in the Geographic Information System ArcView. These data were transformed into a tree using the unweighted pair group method using arithmetic averages (UPGMA) as described in Swofford et al. (1996).

#### **DNA METHODS**

DNA was extracted from whole individuals (except for the largest cirrolanids, where half of the body was used) using a Qiagen DNeasy extraction kit, following the protocol for animal tissues. Minor changes to

the kit protocol included using liquid nitrogen to finely crush specimens in the first step and adding one microliter of 10 micrograms/microliter yeast tRNA after lysis to act as a carrier DNA to help the host DNA bind to the membrane and increase DNA yield. In addition, due to the small body size of the asellids, the DNA was concentrated after the final step using a vacuum centrifuge.

Polymerase chain reaction (PCR) was performed to amplify two mitochondrial genes, a ribosomal RNA (16S) and a protein-coding gene (cytochrome *c* oxidase subunit I). For amplifying the 16S rRNA, the primers used were 16Sar (5'-CGCCTGTTTAACAAAAACAT-3') and 16Sbr (5'-CCGGTCTGAACTCAGATCACGT-3') (Simon et al. 1994). For amplifying COI, the primers used were LCO1490 (5'-GGTCAACAAATCATAAAGATATTGG-3') and HCO2198 (5'-TAACTTCAGGGTGACCAAAAAATCA-3') (Folmer et al. 1994).

After successful amplification, the PCR product was gel purified using a Qiagen QIAEX II kit, following the protocol for agarose gel extraction. The clean PCR product and primer was delivered to the Institute for Cellular and Molecular Biology DNA Sequencing Facility at The University of Texas at Austin where the remaining steps were performed. Those steps included cycle sequencing with Big Dye terminators, removing the unincorporated dye terminators using Centri-Sep spin columns from Princeton Separations, and finally sequencing the sample using an automated sequencer (capillary-based AB3200 and

AB3100). In nearly every population, two individuals were sequenced from both directions to verify the sequences, which were then aligned using ClustalX (Thompson et al. 1997) and MegAlign (DNASTAR).

### **PHYLOGENETIC ANALYSES**

Phylogenetic trees were created using the likelihood criterion with the program PAUP\* (version 4b10) (Swofford 2000). Tree searching was done using successive approximation. An initial parsimony tree was obtained using TBR branch swapping on 100 random stepwise addition replicates. A likelihood-ratio test was employed in order to select the model of sequence evolution; both isopod groups were found to fit the GTR + I +  $\Gamma$  (general time reversible, invariant sites and gamma distribution of rate heterogeneity) evolutionary model. The parameters were then estimated on this parsimony tree and fixed. The next tree search also used TBR branch swapping on 100 random stepwise addition replicates under the likelihood criterion. Parameters were then re-estimated on this maximum-likelihood tree and fixed for a second round of searching. This was continued until the maximum-likelihood trees recovered in the last two passes of successive approximation were identical (two passes in Cirolanidae, three in Asellidae), and the likelihood-based parameters from the final pass were used in the final tree.

For a measure of reliability of the branches, non-parametric bootstrapping was performed using 200 pseudo-replicate datasets, NNI branch swapping, and evaluated using maximum likelihood. Bayesian

posterior probabilities were calculated under the same evolutionary model (GTR + I +  $\Gamma$ ) using MrBayes v2.01; (Huelsenbeck and Ronquist 2001). Four Monte Carlo Markov chains (MCMC) were run for 4 million generations. The first 100,000 generations (= 1,000 trees) were discarded to ensure the Markov chain had reached equilibrium. For the analysis, one tree was sampled every 100 generations for a total of 40,000 trees.

### **TESTING ABIOTIC HYPOTHESES**

Three methods were used to compare the gene trees obtained from *Lirceolus* and *Cirolanides* DNA to the three different abiotic trees (based on subterranean hydrogeology, surface rivers, and geographic distances). The first method compared the likelihood score of each abiotic tree given the genetic data. The best gene tree, without duplicate sequences and outgroups, was searched as discussed above and scored in PAUP\* (version 4b10) (Swofford 2000) using maximum likelihood. The abiotic trees defined a set of constraints that were placed on this gene tree, then another successive approximation search using maximum likelihood was used to find constrained trees, which were given likelihood scores. Each of the multiple options for the hydrology trees were considered for this analysis, such that there were 16 trees for the *Cirolanides* hydrology and 8 trees for the *Lirceolus* hydrology. These likelihood values were simply ranked to determine which abiotic hypothesis best fit the genetic data.

The second method used to evaluate congruency of the datasets was a parsimony-based approach in the program TreeMap v 1.0a (Page



1994). This program maximizes the number of shared nodes, or cospeciation events, between two trees. Secondly, a randomization test was performed to test the hypothesis that the number of cospeciation events between the two trees is the same as would be expected between one given tree (the abiotic tree) and another random tree (a randomized gene tree). The distribution of cospeciation events in the randomized sample is compared to the actual number of cospeciation events to obtain a significance value. The settings used included heuristic searches for maximizing cospeciation events between the two given trees, and 1000 random trees created using the Yule (Markovian) model.

The final analysis was parametric bootstrapping of constraint trees targeting clades of particular interest (Hillis et al. 1996; Huelsenbeck et al. 1996). Five constraint trees for *Lirceolus* and nine constraint trees for *Cirolanides* targeted hydrogeologic questions raised by the isopod phylogenies. To perform these tests, the outgroup and all taxa with exact duplicate sequences were eliminated from the gene trees unless they were the only representative of a population. Successive approximation was used to find the new best tree which was then scored in the same manner as the original gene trees, using maximum-likelihood in PAUP\* (version 4b10) (Swofford 2000). Fourteen model trees, constrained to the topology of each of the hypotheses, were also estimated this way.

Using each model tree and its appropriate model of sequence evolution (as determined by a likelihood ratio test), 100 simulated datasets

were created using Seq-Gen (Rambaut and Grassly 1997). Each of these simulated datasets had two heuristic searches performed on it, one to find the overall best tree and the other to find the best tree compatible with the constraint that was used to create the model tree. The difference of these two scores on the simulated datasets was the distribution of expected differences for each hypothesis being tested. The observed difference between the best tree and the best constraint tree, using the actual data, was then directly compared to this expected distribution to obtain a significance value (Hillis et al. 1996; Goldman et al. 2000).

## Results

This section details the three alternative abiotic trees created using a literature review, the gene trees created from sequencing in this project, and the comparison of these gene trees with the three alternative hypotheses.

### ABIOTIC HYPOTHESES

#### Subterranean Hydrogeology

Figure 2 summarizes known and probable subterranean hydrogeologic relations (based on non-biological data) among sites where *Cirolanides* were collected. In four cases, two alternative placements of a branch were possible, and both are illustrated. For calculation of likelihood scores for the abiotic trees and for TreeMap, all 2<sup>4</sup> topological options were tested (four sites on the tree with two possible placements, see Figure 2).

Characters defining the subterranean hydrogeologic tree (as indicated in Figure 2) are listed below. Most of the hydrogeologic history is based on Veni (1994a), and estimates of many of large-scale relationships are based on potentiometric surface data (Kuniansky and Holligan 1994). Many large-scale relationships supporting a general west to east direction of aquifer evolution, and therefore cave development, are based on dating of cave features summarized by Veni (1994a) and unpublished data (Veni,

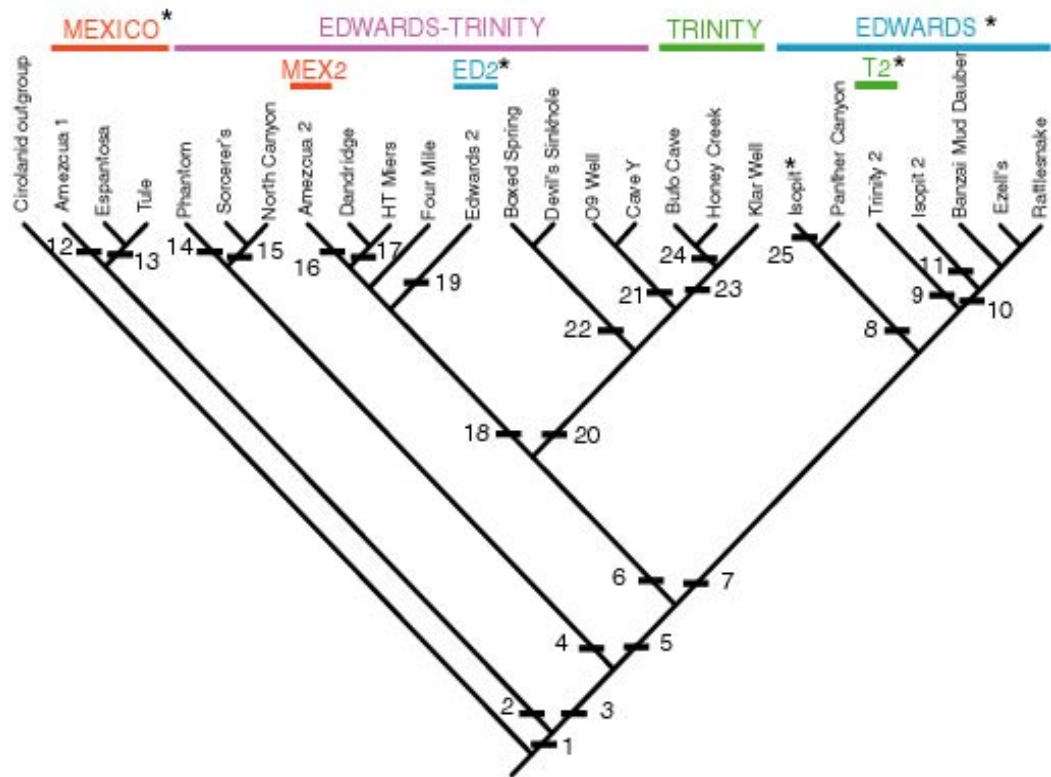

Fig. 2. Abiotic tree showing relationships between *Cirolanides* localities based on subterranean hydrogeology. Long colored bars represent aquifers the sites occur in and short colored bars show alternative placements for aquifers (MEX2 = alternative placement on tree for Mexico clade, ED2 = alternative placement of Edwards Aquifer clade, TR = Trinity Aquifer, T2 = alternative placement of Trinity Aquifer clade). Full names of sites are given in Appendix I. Asterisks indicate the best ranking location when two options for a clade were tested using maximum likelihood as in Table 1. In the case of the Edwards Aquifer, the two placements had equal maximum likelihood values.

in prep.). Regional information on subterranean hydrogeology is cited in the following list of characters (numbers correspond to those in Figure2):

1. Initial cave invasion was from an assumed single marine population that lived on the historic shallow sea floor during Cretaceous deposition (and some erosion) of limestone units over the land mass that is currently Texas and northern Mexico; the cavernous Cretaceous units examined in this study were deposited 113 to 83 mya.
- 2, 3. There are no specific data on timing of isolation of these sites. However, sites on opposite sides of the Rio Grande (2 is south, 3 is north), which, along with the Pecos River, became a dominant stream system as a result of Laramide mountain building to the west, could have been isolated as early as the Eocene (Veni 1994a). These rivers probably began cutting into the Edwards Limestone during Miocene (as a result of Balcones Faulting) and the meanders were preserved in the late Miocene and early Pliocene time, delimiting the boundaries of the Edwards Plateau (Veni 1994a). This cladogenic event thus took place sometime between 54 and 2 mya, though subsequent major downcutting of the river occurred again in the early Pleistocene. The Rio Grande was chosen as the most ancestral node because the Edwards-Trinity Aquifer is shown on hydrology maps as ending at the Rio Grande, which implies a more significant divide than the Pecos, although the actual difference in timing of downcutting of the Rio

Grande and Pecos is unstudied, making this placement somewhat arbitrary.

- 4, 5. Sites on opposite sides of the Pecos River (4 is west, 5 is east) on the Stockton Plateau (54 to 2 mya, see description in character 2).
- 6, 7. Sites in the Trinity and Edwards-Trinity aquifers (collectively, character 6) were separated from the Edwards Aquifer (character 7) during Balcones faulting (23 – 5 mya).
8. Sites in the Comal Springs groundwater drainage basin, or the South Central Flow Unit of the Edwards Aquifer, which formed as a result of Guadalupe River downcutting that exposed the limestone along a permeable fault zone at the potentiometric surface where Comal Springs could form (Maclay and Land 1988).
9. Trinity Aquifer sites have this placement because of their deep connection to the Edwards Aquifer. This option is supported by proven subterranean connections between Cibolo Creek and Guadalupe River via Honey Creek Cave, and occurrence of the cave dwelling salamander, *Eurycea tridentifera*, in both the Guadalupe River and Cibolo Creek drainages, the latter known to be pirated into the Edwards Aquifer (Veni 1997b; Chippindale et al. 2000).
10. Sites in the San Marcos Springs groundwater drainage basin, or the Eastern Flow Unit of the Edwards Aquifer, formed as Blanco River downcutting exposed the limestone along a permeable fault

zone at the potentiometric surface where San Marcos Springs could form (Maclay and Land 1988).

11. A single site occurs in the Austin Chalk formation, and it could be related to nearby Edwards Aquifer caves such as Banzai Mud Dauber Cave via a shallow connection that may or may not currently exist, in which case it is most closely related to sites in the San Marcos Springs drainage.
12. This site probably drains directly into the Rio Grande (Hendrickson et al. 2001).
13. These sites both drain into the Rio Sabinas.
14. The stream in Phantom Lake Cave drains to the east, and is located far from all other Stockton Plateau sites (Tucker 2000).
15. These Stockton Plateau sites drain southeast. Sorcerer's Cave probably discharges to the Rio Grande (Veni 1994b), although North Canyon Spring drains into Independence Creek, a Pecos River tributary. These two are considered separate from the other Stockton Plateau site, Phantom Lake Cave, because distance and direction of flow indicate a probable drainage divide between them, though no barrier to groundwater connectivity is known.
16. This locality in northern Mexico would be most closely related to the Del Rio sites if the Rio Grande is not a significant barrier.
17. These two localities drain into the Devil's River and are joined by continuous cavernous limestone on the east side of the river.

18. The Del Rio localities are joined by proximity and continuous cavernous limestone.
19. The Edwards Aquifer sites are alternatively related to the Edwards-Trinity Aquifer via connection of the aquifers in Kinney County, given that genetic communication may have been maintained, currently or in the recent past, across the Kinney groundwater divide shown in Figure 1 (e.g., stygobites can swim upstream and across groundwater divides).
20. These sites make up the remainder of the Edwards-Trinity Aquifer, outside of, and upgradient from, the Del Rio area and potentially related sites in the Trinity Aquifer (see character 23).
21. These two sites are probably relatively young Edwards-Trinity Aquifer caves. They occur near the northern margin of the Edwards Plateau and are formed underneath relatively poorly permeable Buda Limestone, which likely prevented significant speleogenesis until eroded to allow sufficient recharge into the underlying Edwards Limestone.
22. These two Edwards-Trinity Aquifer sites are in a relatively high potentiometric region and therefore may be older than the other sites in this branch. Specific evidence for timing of this node does not exist, so placement is somewhat arbitrary.
23. Sites in the Trinity Aquifer may be more related to sites in the Edwards-Trinity Aquifer than they are to Edwards Aquifer sites if



shallow connections between them were the path for isopod migration. This option was also considered despite the fact that modern hydrology does not support this hypothesis because non-cavernous and poorly permeable areas in the upper member of the Glen Rose Formation in Kendall, Kerr, and Medina counties divide the Trinity Aquifer from the Edwards-Trinity Aquifer along most of their boundaries.

24. Although these two caves have not been physically or hydrologically connected, their proximity and position suggest that Bufo Cave drains into Honey Creek Cave.
25. The only site in the Austin Chalk may be related to other sites via a deeper connection with the Edwards Aquifer caves that recharge Comal Springs, such as Panther Canyon, and possibly deeper connections to Ezell's Cave and Rattlesnake Cave.

The tree in Figure 3 summarizes known and probable subterranean hydrogeologic relations among *Lirceolus* collection sites. In three cases, there were two options for branch placement, and both are shown. For calculations of likelihood scores for abiotic trees and for the TreeMap analysis, all  $2^3$  topological options were tested (three sites with two possible placements). Characters determining this tree (numbered as in Figure 3) are as follows:

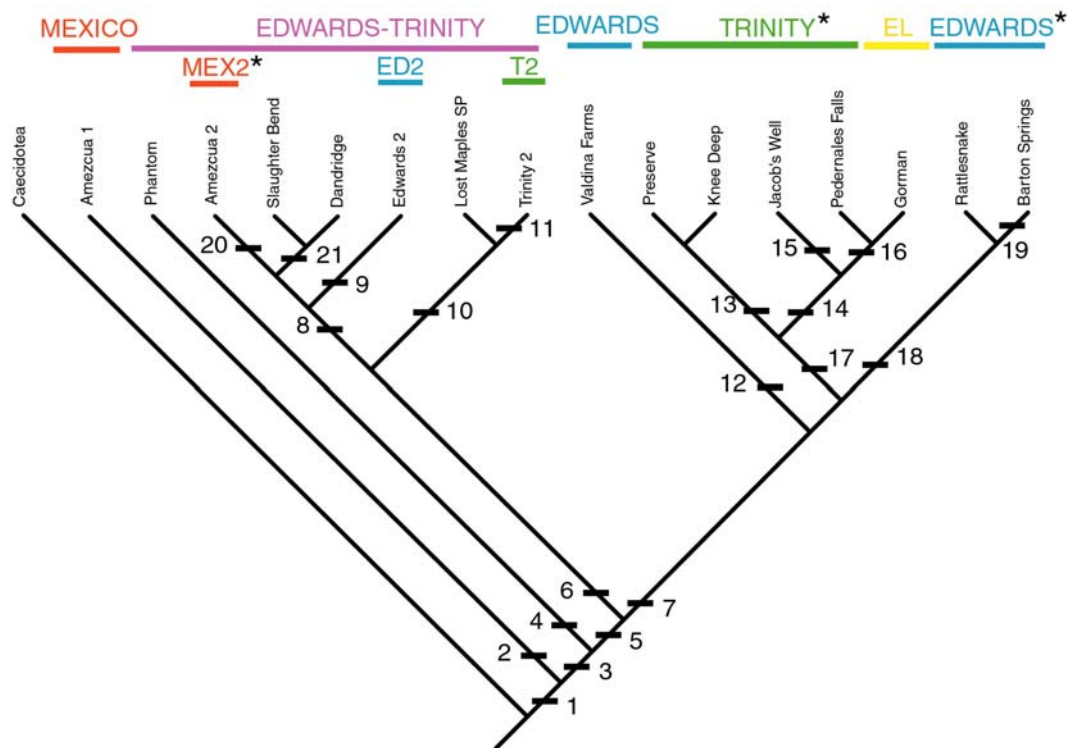

Fig. 3. Abiotic tree showing relationships between *Lirceolus* localities based on subterranean hydrogeology. Long colored bars represent aquifers the sites occur in and short colored bars show alternative placements for aquifers (MEX2 = alternative placement on tree for Mexico clade, ED2 = alternative placement of Edwards Aquifer clade, T2 = alternative placement of Trinity Aquifer clade). Full names of sites are given in Appendix I. Asterisks indicate the preferred location when two options for a clade were tested using maximum likelihood as in Table 1.

1. The genus *Lirceolus* is endemic to Texas and North Mexico, thus monophyly is assumed for cave-invading ancestors of *Lirceolus*. Some genetic differentiation of surface populations may have occurred prior to cave invasion, but these possibilities are too complex to formulate on a series of trees, and will be treated later

in the discussion. Assuming that this species was never salt water tolerant, cave invasions could have taken place as early as the end of the Cretaceous or early Tertiary when the Laramide Orogeny uplifted Texas from the ocean for the final time (approximately 60 mya).

- 2, 3. Sites on the north (2) and south (3) side of the Rio Grande (54 to 2 mya, see description in characters 2 and 3 of *Cirolanides* description).
- 4, 5. Sites on the west (4) and east (5) side of Pecos River, on the Stockton Plateau (54 to 2 mya, see description in character 2 of *Cirolanides* description).
- 6, 7. Sites in the Trinity and Edwards-Trinity aquifers (collectively, character 6) which were separated from the Edwards Aquifer (character 7) during Balcones faulting (23 – 5 mya).
8. Localities around Del Rio are joined by proximity and continuous cavernous limestone.
9. One option for the Edwards Aquifer sites is that they are related to the Edwards-Trinity Aquifer via connection of the aquifers in Kinney County, with genetic communication maintained, currently or in the recent past, across the groundwater divide there by organisms migrating upstream.
10. Lost Maples State Park spring could be most closely related to the Trinity Aquifer sites if there is a shallow subsurface connection

between this upgradient site on the Edwards Plateau and the downgradient sites in the Trinity Aquifer.

11. Sites in the Trinity Aquifer may be more related to sites in the Edwards-Trinity Aquifer if shallow connections between them were the path for isopod migration. Modern hydrology, however, does not support this hypothesis because of the non-cavernous and poorly permeable areas in the upper member of the Glen Rose Formation in Kendall, Kerr, and Medina counties that divide the Trinity Aquifer from the Edwards-Trinity Aquifer along most of their boundaries.
12. Sites in the Comal Springs groundwater drainage basin, or the South Central Flow Unit of the Edwards Aquifer, formed as a result of Guadalupe River downcutting that exposed the limestone along a permeable fault zone at the potentiometric surface where Comal Springs could form (Maclay and Land 1988).
13. These geographically proximal sites are both south of the Guadalupe River and in the Cow Creek Limestone with no evidence for discontinuous cavern development between them.
14. These sites all occur north of the Guadalupe River, a local groundwater trough that separates them from sites south of the river.

15. Jacob's Well is in a cavernous portion of the lower member of the Glen Rose Formation, separating it from Pedernales Falls Spring and Gorman Cave that occur in other formations.
16. These two sites may be related because they occur in limestone that is continuous, but narrow between the sites (Marble Falls and Cow Creek Formations).
17. Sites in the Trinity Aquifer have this placement given that there is a deep connection to the Edwards Aquifer (see character 9 of *Cirolanides* description).
18. Sites in the San Marcos Springs groundwater drainage basin, or the Eastern Flow Unit of the Edwards Aquifer (Maclay and Land 1988), and in the Barton Springs segment of the Edwards Aquifer. Even though there is a modern groundwater divide between San Marcos Springs and Barton Springs, there is no evidence of a non-cavernous barrier to organism movement or a barrier to high water connections.
19. This site is in the Barton Springs segment of the Edwards Aquifer, where Barton Springs formed as a result of Colorado River downcutting that exposed the limestone along a permeable fault zone at the potentiometric surface.

### **Surface Rivers**

The river trees in Figures 4 and 5 represent the four main river systems in the study area with a basal polytomy where they drain into the

Gulf of Mexico. Polytomies were also invoked where several sites drained into the same river and there was no particular reason for any of those locations to be more closely related than others.

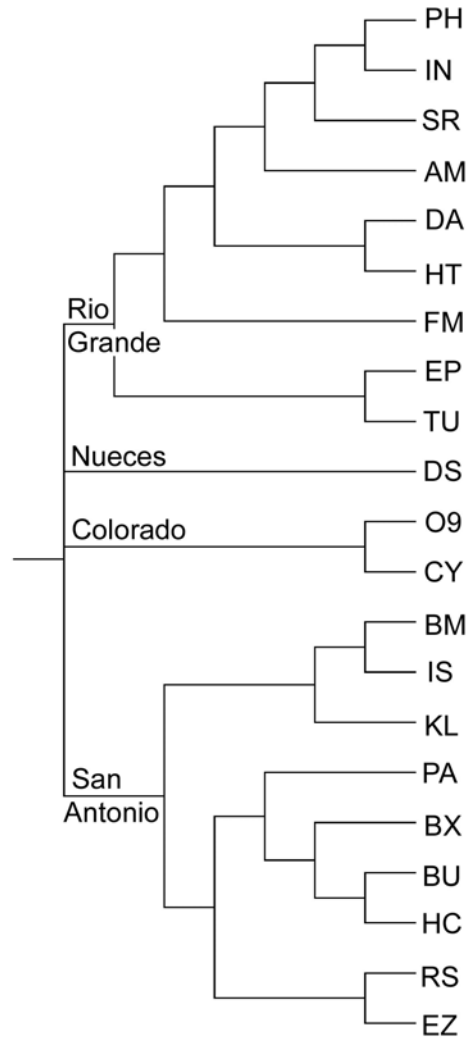

Fig. 4. The river tree for *Cirolanides* collecting localities. Full names of sites are given in Appendix I.

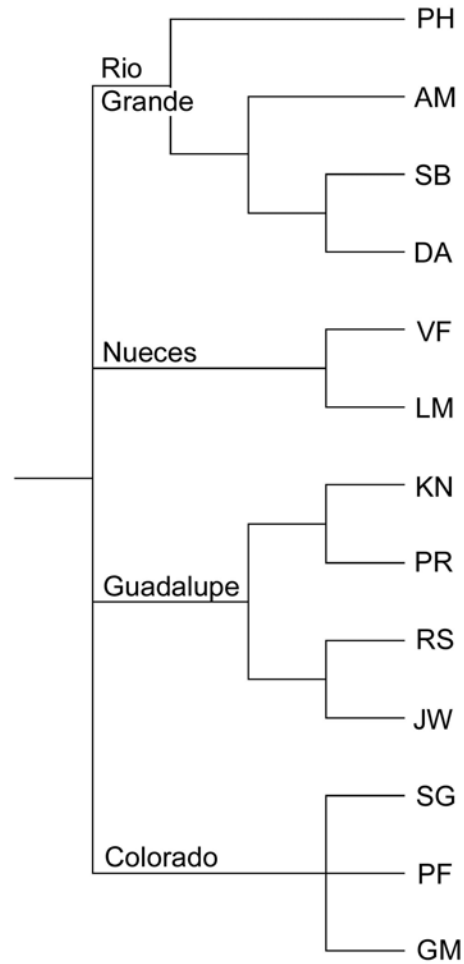

Fig. 5. The river tree for *Lirceolus* collecting localities. Full names of sites are given in Appendix I.

### Distance Matrix

Trees obtained using matrixes of geographic distances among sites are shown in Figures 6 and 7. Although branch lengths were created in the

initial distance matrix, only the topology shown in the figures was used for analysis.

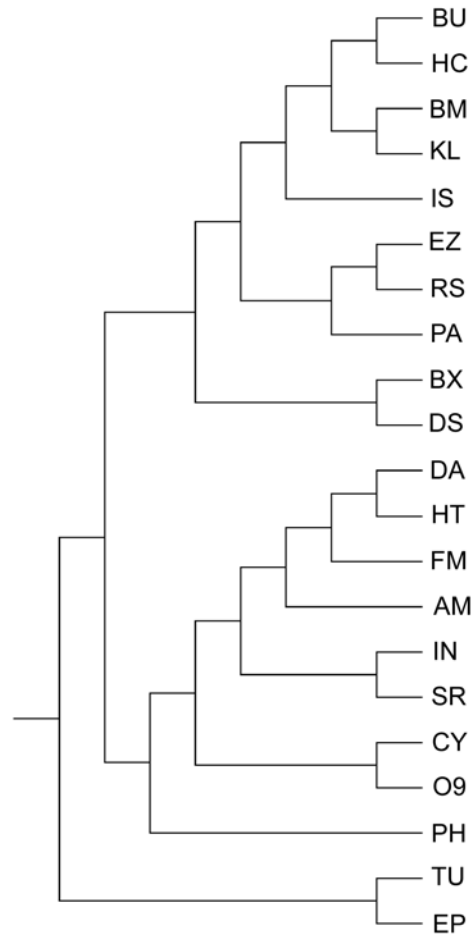

Fig. 6. Distance matrix tree showing relationships of sites where *Cirolanides* were collected. Full names of sites are given in Appendix I.



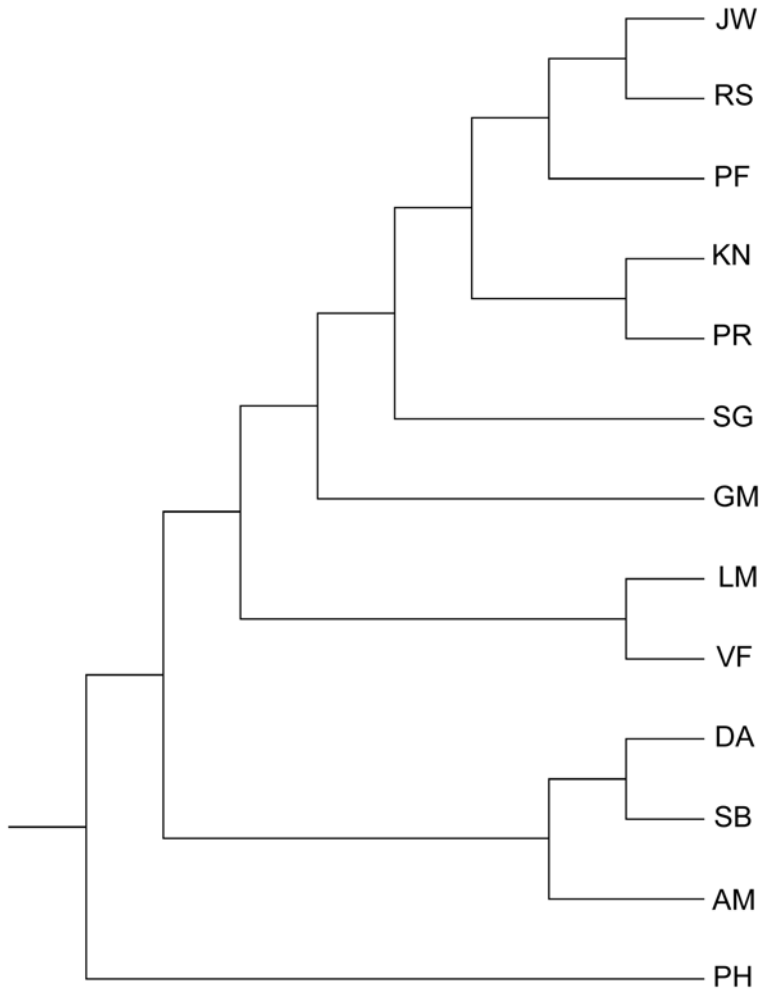

Fig. 7. Distance matrix tree showing relationships of sites where *Lirceolus* were collected. Full names of sites are given in Appendix I.

## GENE TREES

In most samples of *Cirolanides*, 465 base pairs were sequenced (ranging from 464-471 base pairs) from the mitochondrial 16S ribosomal RNA (16S rRNA) gene and 658 base pairs were sequenced (ranging from 646-659 base pairs) from the mitochondrial cytochrome *c* oxidase subunit I (CO1) gene. In most samples of *Lirceolus*, 476 base pairs were sequenced (ranging from 471-492 base pairs, except two samples of 231 base pairs) from the mitochondrial 16S rRNA gene and 658 base pairs were sequenced (ranging from 281-658 base pairs) from the mitochondrial CO1 gene. GenBank accession numbers for these sequences are given in Appendix I. For each family, a partition homogeneity test was used in order to verify that the two genes, 16S and CO1, support the same tree. In this test, both groups of isopods were found to have high *p* values (Asellidae,  $p = 0.28$ , Cirolanidae,  $p = 0.88$ ), therefore the hypothesis that the two genes were drawn from the same population could not be rejected, and thus the genes were combined. Maximum likelihood trees and accompanying non-parametric bootstrap values and Bayesian posterior probabilities are shown in Figures 8 - 10.

Genetic variation within populations of cave isopods was nearly always smaller than among populations, allowing a gene tree to be constructed that had each population as a terminal node. For two populations, Ezell's Cave for *Cirolanides* and Knee Deep Cave for *Lirceolus*, there was sufficient within-population genetic variation that they

were paraphyletic in the maximum likelihood phylogenetic estimation. However, in both cases there was strong support for monophyly of the next deepest node, allowing a simplified gene tree to be used for comparison to the abiotic trees.

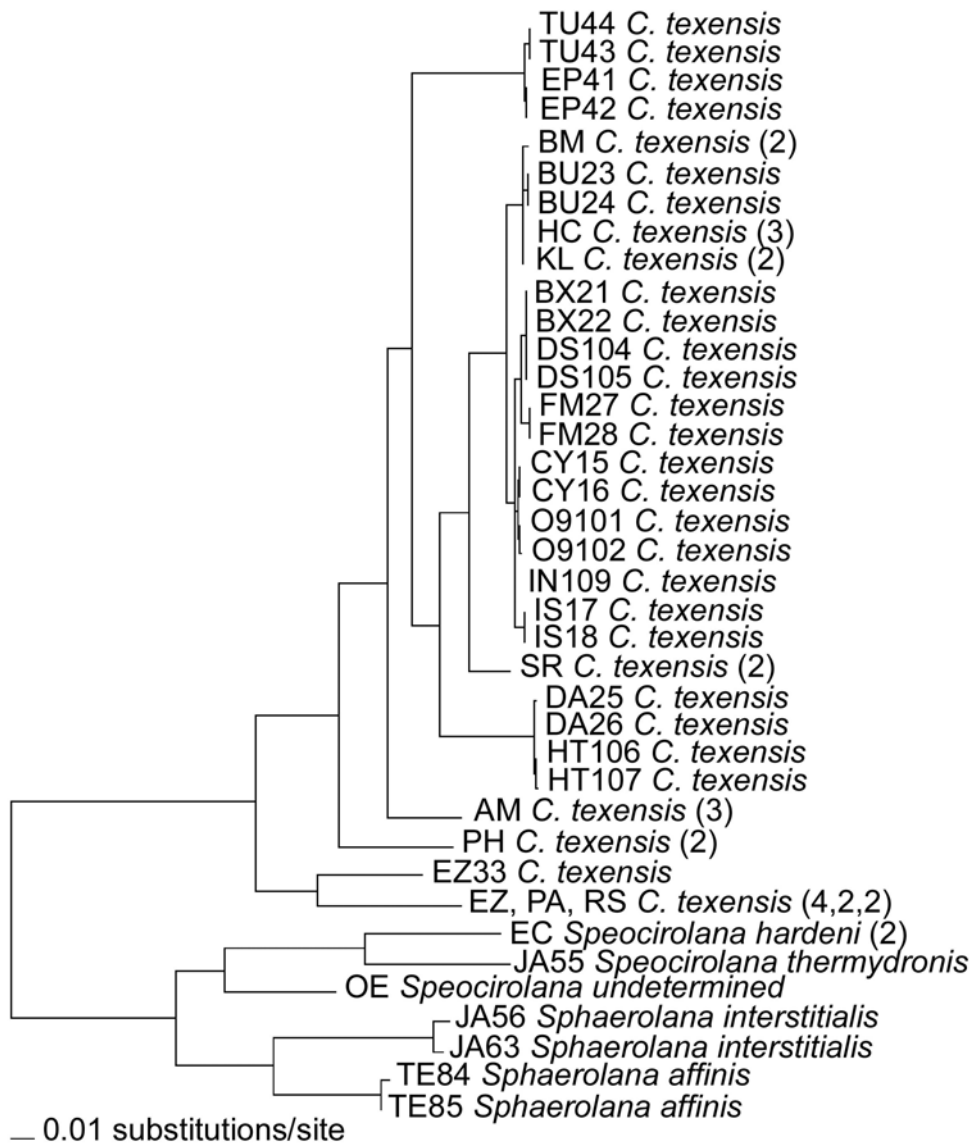

Fig. 8. *Cirolanides* gene tree based on the criterion of maximum likelihood. Two letter site codes are detailed in Appendix I. Numbers in parentheses indicate the total number of individuals from each population with identical sequences, thus the sister taxon that was collapsed had 100/100 bootstrap and Bayesian support.

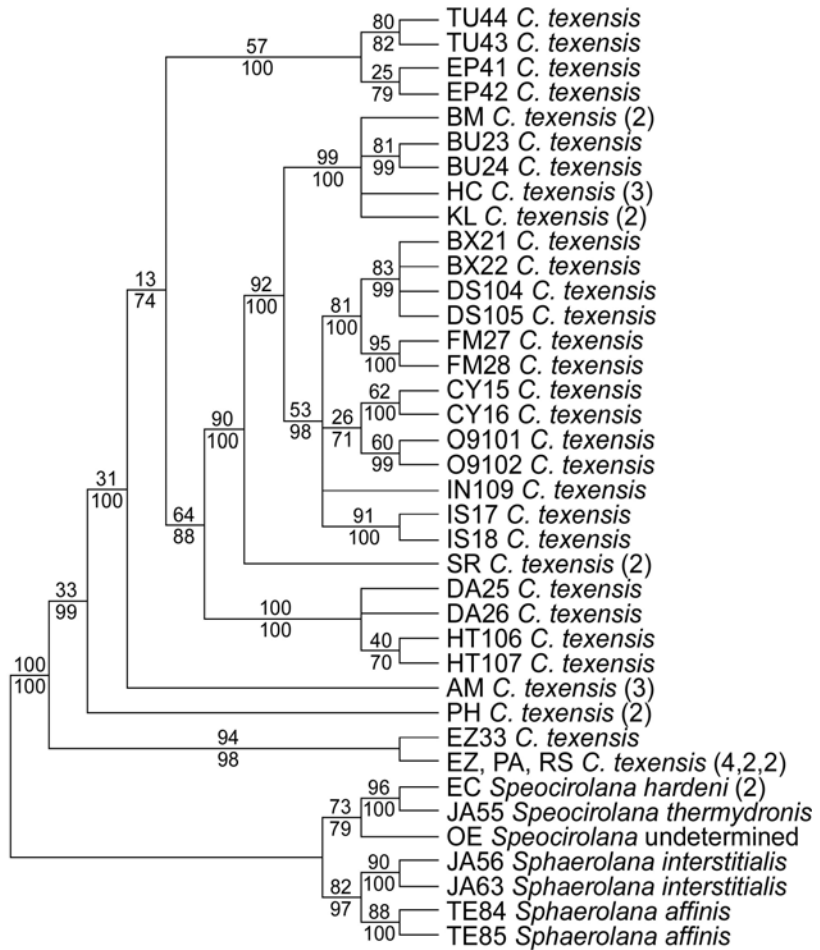

Fig. 9. *Cirolanides* gene tree based on the criterion of maximum likelihood, showing non-parametric bootstrap values (top) and Bayesian posterior probabilities (bottom). Two letter site codes are detailed in Appendix I. Numbers in parentheses indicate the total number of individuals from each population with identical sequences, thus the sister taxon that was collapsed had 100/100 bootstrap and Bayesian support.

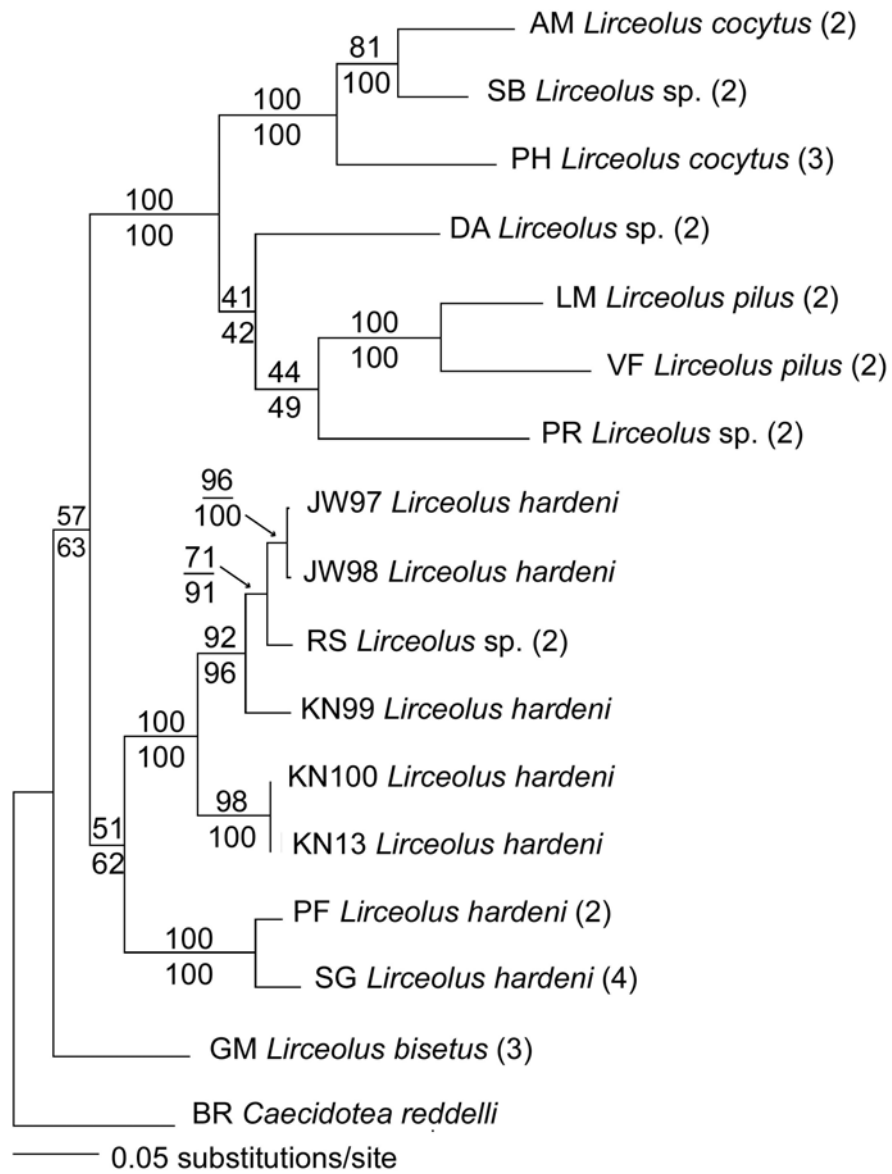

Fig. 10. *Lirceolus* gene tree based on the criterion of maximum likelihood. Two letter site codes are detailed in Appendix I. Non-parametric bootstrap values (top) and Bayesian posterior probabilities (bottom) show support for each node. Numbers in parentheses indicate the total number of individuals from each population that formed a clade with 100/100 bootstrap and Bayesian support.

## TREE COMPARISON

Figure 11 demonstrates that for *Cirolanides*, the basal nodes of the gene phylogeny were incongruent with the subterranean hydrogeology hypothesis but many terminal nodes matched well. In contrast to this, the *Lirceolus* gene tree was entirely incongruent with the subterranean hydrogeology hypothesis (Figure 12) but was similar to the surface river hypothesis (Figure 13).

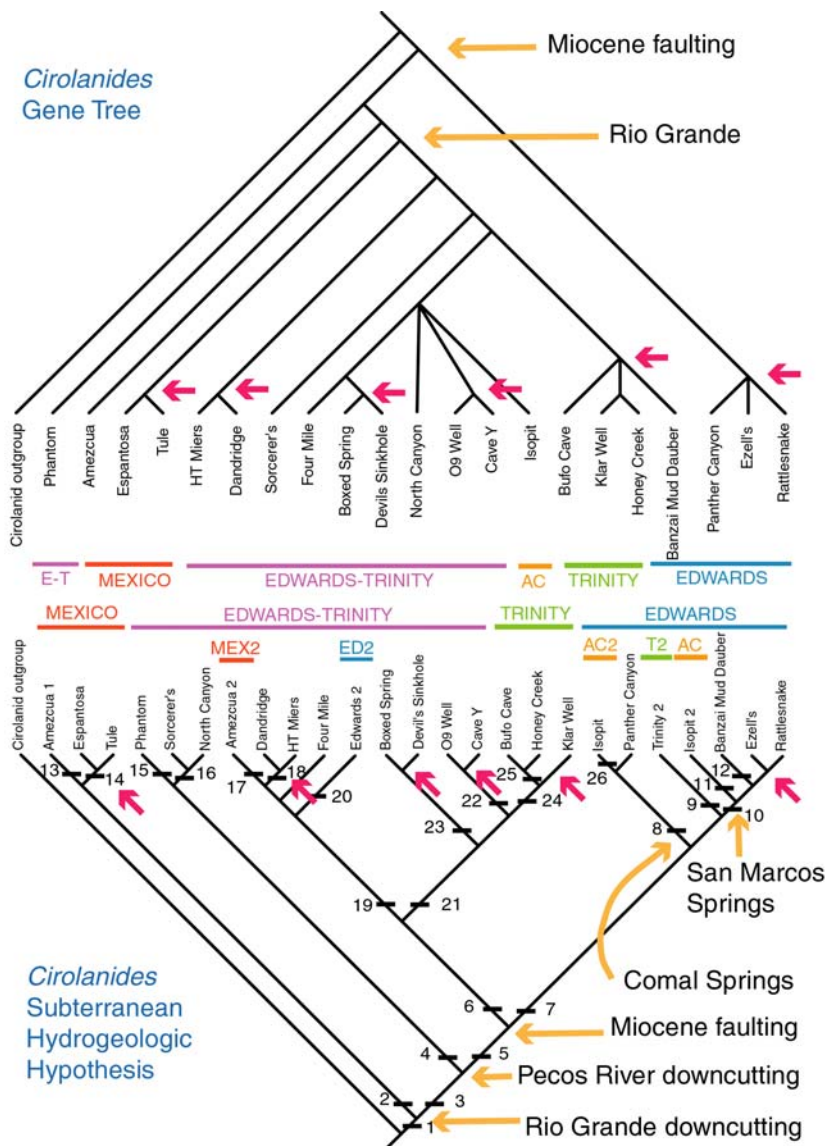

Fig. 11. Comparison of *Cirolanides* gene tree and subterranean hydrogeology tree. Pink arrows show recent congruencies whereas orange arrows show historic events where timing was not perfectly predicted by the hydrogeology tree. Long colored bars represent aquifers sites occur in and short colored bars show alternative placements for aquifers (MEX2 = alternative placement on tree for Mexico clade, ED2 = alternative placement of Edwards Aquifer clade, T2 = alternative placement of Trinity Aquifer clade, AC = Austin Chalk, E-T = Edwards-Trinity Aquifer). Full names of sites are given in Appendix I.



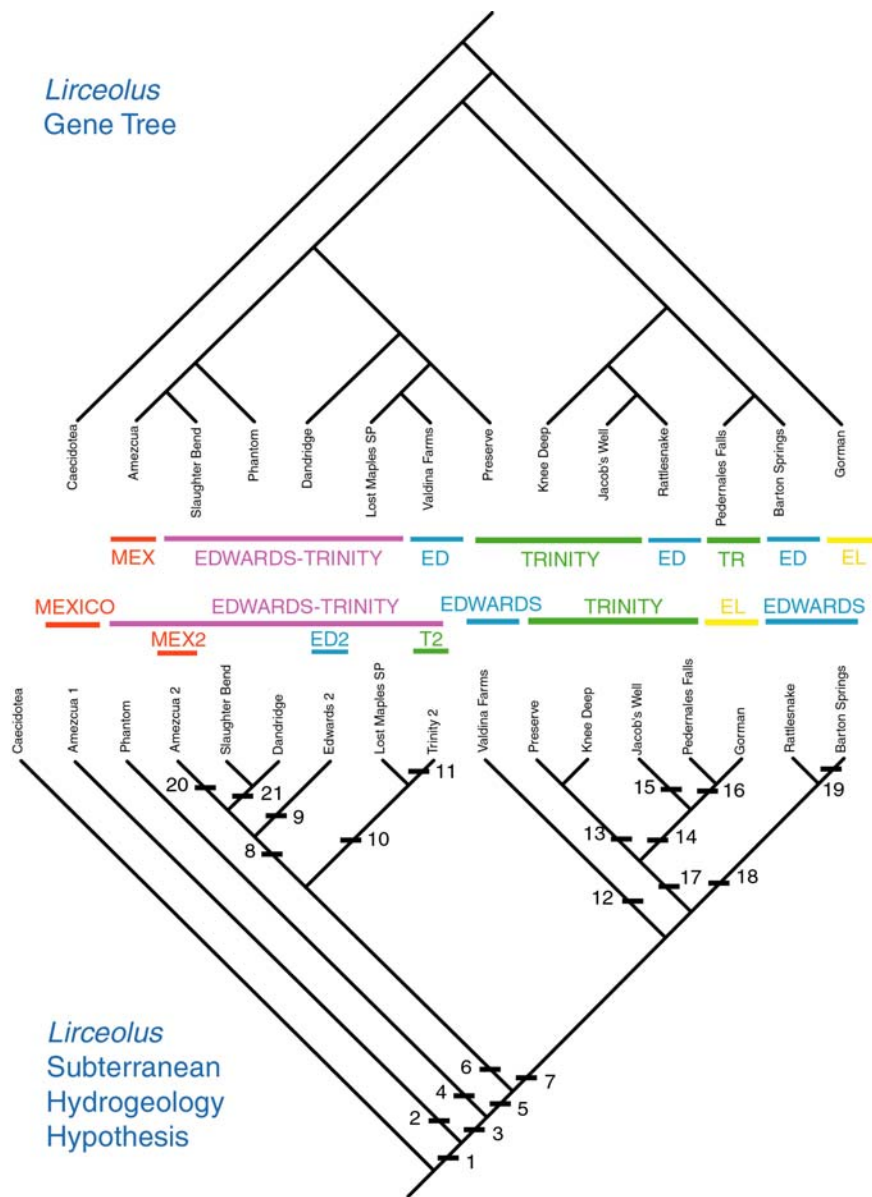

Fig. 12. Comparison of *Lirceolus* gene tree and subterranean hydrogeology tree. Long colored bars represent aquifers sites occur in and short colored bars show alternative placements for aquifers (MEX2 = alternative placement on tree for Mexico clade, ED = Edwards Aquifer, ED2 = alternative placement of Edwards Aquifer clade, TR = Trinity Aquifer, T2 = alternative placement of Trinity Aquifer clade, EL = Ellenburger formation). Full names of sites are given in Appendix I.

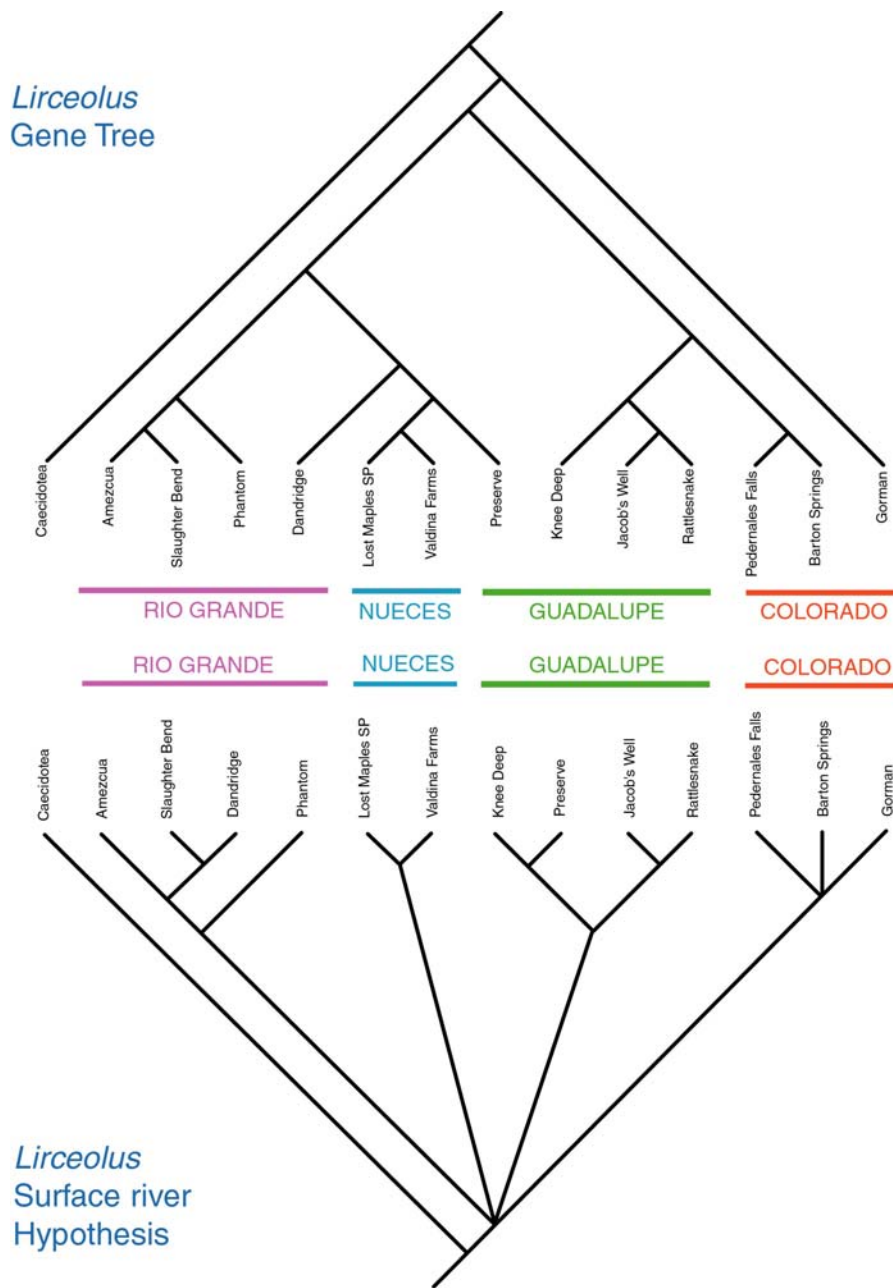

Fig. 13. Comparison of *Lirceolus* gene tree and surface river tree. Colored bars show major surface river basins that sites occur in. Full names of sites are given in Appendix I.

Table 1. Comparison of gene trees and abiotic trees using maximum likelihood ranks and TreeMap randomization test. Section A includes best fit ranked as the negative log likelihood scores (-lnL) nearest to the gene tree. Scores of only the best abiotic trees were given when there were multiple abiotic trees tested, as in the subterranean hydrogeology. Section B includes best fit ranked as the highest number of cospeciation events, and an asterisk (\*) denotes significantly more cospeciation events than would be expected with a random tree at the alpha level of 0.05.

<b>A. Maximum Likelihood Rank Comparison</b>		
<b>Taxon and Ranking of Abiotic Tree</b>		<b>-ln L</b>
<i>Cirolanides</i> (best tree)		3764.0
#1 Distance matrix		3861.3
#2 Subterranean hydrogeology (best two topologies of 16)		4162.7
#3 Surface rivers		4240.1
<i>Lirceolus</i> (best tree)		6709.7
#1 Surface rivers		6834.4
#2 Distance matrix		6979.8
#3 Subterranean hydrogeology (best two topologies of 8)		7189.2
<b>B. TreeMap Randomization Comparison</b>		
<b>Taxon and Ranking of Abiotic Tree</b>	<b># cospeciation events</b>	<b>p</b>
<i>Cirolanides</i>		
#1 Subterranean hydrogeology, topology 1	10	0.007<p<0.025*
Subterranean hydrogeology, topology 2	10	0.002<p<0.018*
#2 Distance matrix	9	0.018<p<0.070
#3 Surface rivers	8	0.043<p<0.190
<i>Lirceolus</i>		
#1 Surface rivers	9	p<<0.001*
#2 Distance matrix	8	P<0.001*
#3 Subterranean hydrogeology, topology 1	6	0.013<p<0.090
Subterranean hydrogeology, topology 2	6	0.015<p<0.089

The maximum likelihood scores of each of the abiotic trees constrained on the genetic data are presented in Table 1. In the case of

*Cirolanides*, the most congruent tree was the distance matrix, although for the *Lirceolus* the most congruent tree was the surface rivers.

The results of the TreeMap v 1.0a (Page 1994) randomization tests are given in Table 1. For *Cirolanides*, the gene tree and the two optimal subterranean hydrogeology trees each shared ten cospeciation events, which is significantly more similar ( $0.007 < p < 0.025$  and  $0.002 < p < 0.018$ ) than would be expected between the abiotic tree and a random tree. The other two abiotic trees shared nine and eight cospeciation events with the gene tree, numbers that are not significantly different ( $0.018 < p < 0.070$  and  $0.043 < p < 0.190$ , respectively) than random trees. Clearly this test ranks the subterranean hydrogeology as most congruent with the *Cirolanides* phylogeny, but it is worth noting that the other randomization tests were not found significant in a conservative interpretation of the p value, but the range of p values included those less than 0.05. For *Lirceolus*, the rank order of competing abiotic hypotheses was identical to that in the maximum likelihood ranking.

For the final analysis, twelve hypotheses were created based on specific incongruencies between the gene trees and the subterranean hydrogeology and river trees, and these hypotheses were tested using parametric bootstrapping. Results are summarized in Table 2.

Table 2. Summary of constraint trees including results of parametric bootstrapping. The description of the constraint trees indicates the grouping of populations whose monophyly is being tested. In these descriptions, note that the *Cirolanides* Edwards Aquifer sites = (PA, RS, EZ), the *Cirolanides* Edwards-Trinity Aquifer sites = (PH, HT, DA, SR, FM, BX, DS, IN, O9, CY, IS, BM), the *Lirceolus* Edwards-Trinity Aquifer sites = (DA, SB, PH, LM), with two letter site codes as in Appendix I. A significant p value (asterisk) indicates that the proposed monophyletic grouping is rejected.

<b>Constraint tree</b>	<b>Best constraint</b>	<b>best tree</b>	<b>observed difference</b>	<b>p</b>
<i>Cirolanides</i> (Isopit, Banzai Mud Dauber, Edwards)	3829.78	3764.01	65.77	<0.01*
<i>Cirolanides</i> (Isopit, Edwards)	3787.47	3764.01	23.45	<0.01*
<i>Cirolanides</i> (Banzai Mud Dauber, Edwards)	3789.73	3764.01	25.72	<0.01*
<i>Cirolanides</i> (all Texas populations)	3764.83	3764.01	0.82	<0.07
<i>Cirolanides</i> (Four Mile Cave, Dandridge, HT Miers)	3794.73	3764.01	30.72	<0.01*
<i>Cirolanides</i> (Amezcuca, Dandridge, HT Miers)	3767.41	3764.01	3.40	<0.03*
<i>Cirolanides</i> (Edwards-Trinity)	3811.02	3764.01	47.00	<0.01*
<i>Lirceolus</i> (Knee Deep, Preserve)	6786.18	6709.68	76.49	<0.01*
<i>Lirceolus</i> (Rattlesnake, Sunken Gardens)	6940.70	6709.68	231.02	<0.01*
<i>Lirceolus</i> ( Edwards-Trinity)	6868.57	6709.68	158.88	<0.01*
<i>Lirceolus</i> (Preserve, Knee Deep, Rattlesnake, Jacob's Well)	6777.03	6709.68	67.35	<0.01*
<i>Lirceolus</i> (Phantom, Amezcuca, Slaughter Bend, Dandridge)	6712.42	6709.68	2.73	<0.02*

## Discussion

### SUBTERRANEAN HYDROLOGY

The *Cirolanides* phylogeny shows congruence with subterranean hydrology based on simple examination of the trees, maximum likelihood rank comparison (where subterranean hydrology ranked 2<sup>nd</sup>, but above surface rivers), and TreeMap randomization tests (Figure 11, Table 1). Examination of the gene tree and hydrogeology tree in Figure 11 shows six matching terminal nodes as well as congruence in composition of deeper clades, but not in the exact placement of these clades. These incongruent basal nodes may reflect an incorrect gene tree or some other biological phenomenon that leads to genetic history not following the hydrogeologic setting (such as dispersal across presumed barriers, a time lag between hydrologic and genetic divergence, genetic divergence within a drainage, or any combination therein), but more likely result from incorrect reconstructions of the timing of separation of these areas, a reflection of inadequate hydrogeologic research.

The Rio Grande and Pecos became major stream systems as early as the Eocene (approximately 54 mya) (Veni 1994a), which was before Balcones faulting (approximately 20 to 12 mya), thus these events were placed more basally on the tree (also refer to text describing characters 2 and 3 on the cirolanid hydrogeology tree). It's not known, however, exactly when the downcutting rivers isolated the specific cave drainages

and contributed to speleogenesis to create habitat. Balcones faulting may have isolated the Edwards Aquifer populations from the rest of Texas and Mexico before the Rio Grande cut down through the cavernous limestone. There is some geologic evidence to support this because prior to faulting there was less topographic relief across the Edwards Plateau. Consequently, most of the limestone was saturated and caves were probably not particularly isolated from one another because few would have been truncated by the shallow surface drainages of that time. In this case, populations of isopods on either side of dominant drainages may not have been separated until after faulting increased topographic expression of these drainages, indicating that the gene tree is correct and the hydrogeology is not known precisely enough to make these distinctions. Some work has been done on entrenchment times for ancestral and modern Rio Grande routes far upstream of the study area, in New Mexico, and estimated these times around 3 - 4 mya for the ancestral Rio Grande and 0.7 - 0.5 mya for the modern Rio Grande (Seager et al. 1984). Overall, the timing of river downcutting events in the present study area is very roughly estimated and has received little attention from hydrogeologists. The order of events reconstructed from the genes is likely to represent real phenomena that should be considered in future work. More geomorphologic history data, such as estimation of denudation rates and dating of karst features, are required to refine

estimations of isolation times and to find better correlations between hydrogeology and genetics.

Likelihood and TreeMap comparisons of the gene trees and abiotic trees each showed similar ranking of competing abiotic hypotheses for *Cirolanides* (Table 1). The subterranean hydrogeology always ranked above the surface rivers, these two being *a priori* thought to represent the two most likely scenarios for genetic communication in this species (see proceeding section for discussion of distance matrix). The difference between the two comparisons was in the ranking of the distance matrix tree which was first in likelihood score and second in TreeMap rank.

In contrast to *Cirolanides*, phylogenetic patterns of *Lirceolus* consistently showed little similarity to the subterranean hydrogeology hypothesis, with no visible similarities in the two trees and lowest ranking using likelihood score and TreeMap randomization comparison methods (Figure 12 and Table 1).

### **SURFACE RIVERS**

The *Cirolanides* phylogeny shows no congruence with surface rivers but *Lirceolus* has high congruence to surface rivers based on a simple inspection of the trees and likelihood scores and TreeMap comparisons (Figure 13 and Table 1). This is an unexpected result considering that the taxon is aquifer-adapted, but aspects of its habitat and evolutionary history are markedly different than *Cirolanides* and may have contributed to this pattern. *Lirceolus* are known from eleven cave



sites, but also ten spring sites, one well site and even one alluvial location. The species may thus be less restricted to the cave environment than is *Cirolanides*, and their presence in an alluvial location shows that they may disperse or have genetic communication via alluvial populations in river beds. In addition, *Lirceolus* have freshwater ancestors, probably originating from *Caecidotea* (Lewis and Bowman 1996) that could have migrated from the midwestern U.S. after oceans receded from Texas. Modern *Caecidotea* occur in non-karst areas, and the freshwater ancestors of *Lirceolus* may have used surface rivers to invade the area. If so, there was probably significant genetic structure prior to invasion of cave and spring systems. The longer branch lengths in the *Lirceolus* vs. *Cirolanides* support this hypothesis, given that rates of gene evolution are somewhat consistent for these two taxa. Although this genetic structure may not impact small-scale regional studies of groundwater flow, this study's hypotheses about subterranean connections are dependent on a common ancestor simultaneously invading a large area across many basins. The congruence of the surface river tree and the gene tree support the conclusion that *Lirceolus* has experienced gene flow via surface rivers.

#### **DISTANCE MATRIX**

For *Cirolanides*, the distance matrix ranked first in maximum likelihood value and second in the TreeMap comparison. The distance matrix may be most similar to the gene tree if these organisms travel

equally well through all areas of the subsurface, with or without large cavern development, or the ranking may be due to some other artifact of the test, such as an incorrectly estimated subterranean hydrogeology tree. The presence of *Cirolanides* in wells and springs without known cave passage supports the distance matrix theory, however, at all well and spring sites where the species were collected for this study there are either known voids that the wells intersect or known cave passages near the springs. In general, this taxon is known from cave conduits (29 of 43 sites), with the minority of localities being from springs (4 of 43 sites) and wells (10 of 43 sites). It seems unlikely that *Cirolanides* travels equally easily through both non-cavernous and cavernous subsurface areas because the majority of water flow in karst is through conduits (Worthington et al. 2000), and this water flow probably provides most of the habitat and energy input that aquatic species depend on. The ranking is more likely from an incorrectly estimated hydrogeology tree, which is in turn related to the paucity of data used to create the deep nodes, and a lack of data in areas where hydrogeologic studies are in their early stages (e.g., west Texas and the Austin Chalk of Bexar County). Populations from two major aquifers, the Edwards and Trinity, did basically fall out as monophyletic groups, and the Edwards-Trinity Aquifer as a paraphyletic group, supporting the argument that clades are following the aquifers. Specific tests of these clades are discussed in the parametric bootstrapping section.

The TreeMap randomization test of *Cirolanides* showed that the distance matrix tree and gene tree did not have significantly more cospeciation events than would be expected between the distance matrix and a random tree ( $0.018 < p < 0.070$ ). The different ranking of the two tests is due to the different methods, but also may reflect the fact that the trees created from the competing abiotic hypotheses were not extremely different (see Figures 2 and 6).

In *Lirceolus* the distance matrix ranked second in both maximum likelihood and TreeMap comparisons. The TreeMap comparison, even though ranked second, did share significantly more cospeciation events than the abiotic tree and a random tree ( $p < 0.001$ ).

#### **TAXON CONGRUENCE**

Many authors concur that a study of congruence between an area's history and a species' phylogeny should be corroborated by multiple taxa (Morrone and Crisci 1995), and this study began with that intention. It was found, however, that the taxon with freshwater ancestors and more diverse tolerance for surface habitats had a phylogenetic pattern apparently more strongly determined by surface hydrology, and the taxon with marine ancestors and a strict subterranean existence followed patterns of subterranean hydrogeology. The freshwater origin may have contributed a pre-cave-invasion genetic structure, and certainly if they have the ability to disperse via hyporheic gravels this would affect patterns of communication. *Lirceolus* might still be used for testing subterranean

hydrogeologic hypotheses at a local level, such as within river basins, but not on a wider scale across all central Texas karst aquifers. Taxa with marine ancestors may generally be better for large scale testing because they are more likely to have been one population when they started their path to subterranean adaptation, therefore their phylogeny would more closely track aquifer evolution. These results indicate that total range and evolutionary history of a taxon should be considered before choosing it as an indicator of subterranean hydrogeology.

#### **PARAMETRIC BOOTSTRAPPING**

Results of likelihood and TreeMap comparisons prompted additional *post-hoc* questions about specific subsets of the abiotic hypotheses, and the degree to which they were supported by the genetic data. To address these, parametric bootstrapping was used to compare the gene trees with selected parts of the abiotic relationships hypotheses.

The first unexpected result was that the population in Isopit, which is located in the Austin Chalk formation of western Bexar County, was not closely related to populations of nearby sites in the Edwards Aquifer (see Figures 11 and 14). The geographic proximity of these two geologic units indicates their waters may be shared, but genetic relationships contradict this. The null hypothesis for the parametric bootstrapping is that Isopit is within a monophyletic Edwards Aquifer clade (that includes other Edwards Aquifer populations: Panther Canyon Well, Ezell's Cave, and Rattlesnake Cave). Since the population in Banzai Mud Dauber Cave also did not fall

into the Edwards Aquifer clade as expected, this hypothesis was tested both with and without Banzai Mud Dauber Cave. Both of these hypotheses were rejected ( $p < 0.01$ ), indicating that Isopit clearly does not fall into the Edwards Aquifer clade.

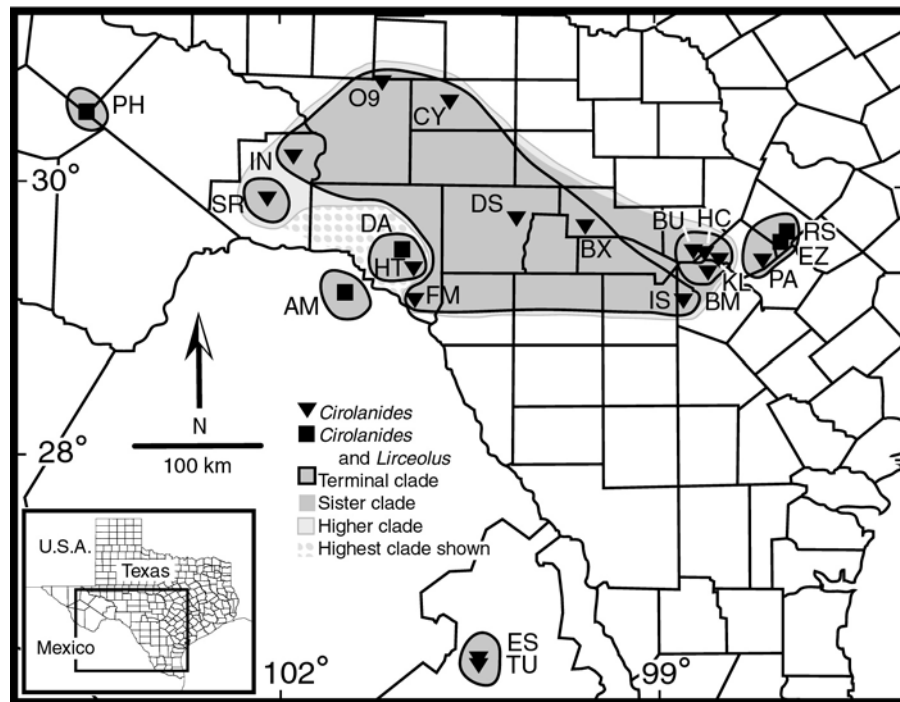

Fig. 14. Map showing genetic relationships of *Cirolanides* localities. Note that Isopit (IS) is not most closely related to nearby Edwards Aquifer sites (PA, EZ, RS), even though they are in close proximity. Also Banzai Mud Dauber Cave (BM) is not most closely related to those same Edwards Aquifer sites (PA, EZ, RS) even though it is formed in the Edwards Limestone group. Finally Four Mile Cave (FM) is not sister to other Del Rio Area sites (DA, HT) as predicted by subterranean hydrogeology. Two letter site codes are listed in Appendix I.

The gene data place the Isopit population within the Edwards-Trinity Aquifer clade which might result from it having been adjacent to

Edwards-Trinity outcrops before significant erosion isolated the cave. While the proximity of karst formations indicates that water most likely currently flows through this Austin Chalk cave, perched above the Edwards Aquifer, and into the Edwards Aquifer, the path down to the Edwards Aquifer may be inhospitable for fauna. Air-filled vertical passage may prohibit free migration between these vertically separated water sources. Also food resources may be limited in the intermediate areas. Another possibility is that Isopit is located closer to a genetic pathway to the Edwards-Trinity Aquifer in the far southwestern part of the Balcones Fault Zone via the Kinney groundwater divide (see Figure 1). Alternatively, Isopit may be the only *Cirolanides* locality sampled in the San Antonio Springs drainage, or Western-Southern Flow Unit of the Edwards Aquifer (Maclay and Land 1988), and there is an ancient barrier to communication with the other flow units. These latter two options require a major barrier to gene flow within the Edwards Aquifer, which is not supported by hydrogeology. Increased sampling in the southwestern part of the Edwards Aquifer and northern and eastern part of the Edwards-Trinity Aquifer would help clarify which of these alternative hypotheses are best supported.

Another result not predicted by hydrogeology is the placement of Banzai Mud Dauber Cave in the Trinity Aquifer clade rather than in the Edwards Aquifer clade (see Figures 11 and 14). This cave is developed in the Edwards Limestone within the Eastern Flow unit of the Edwards

Aquifer, discharging at San Marcos Springs. Recent tracer studies support a deep connection between Banzai Mud Dauber Cave and the Edwards Aquifer (Johnson et al. 2005). The null hypothesis was that Banzai Mud Dauber Cave would be within a monophyletic Edwards Aquifer clade that includes other Edwards Aquifer populations: Panther Canyon Well, Ezell's Cave, and Rattlesnake Cave. This hypothesis was rejected ( $p < 0.01$ ), and the gene data clearly support inclusion of Banzai Mud Dauber Cave in the Trinity Aquifer clade. This finding probably reflects the proximity of the cave to a fault where the upper member of the Glen Rose Formation (which is in the Trinity Aquifer) is juxtaposed with Edwards Limestone (the fault is 170 meters from the cave, Veni, pers. comm.). Isopods from the Trinity Aquifer may be traveling along this fault and passing into the Edwards Limestone through humanly impassable conduits between the fault and the cave. The water in the cave comes from local recharge, and this population may be limited to this water and associated energy entering the cave, with no deep connection to other Edwards Aquifer (Balcones Fault Zone) sites. In this case isopod phylogenies demonstrate recharge from the Trinity Aquifer to the Edwards Aquifer, a topic that has received attention by hydrogeologists studying water budgets for the area (Kuniansky and Holligan 1994; Mace et al. 2000). This demonstrates the need to consider both the unit the cave is formed in as well as area geology when deciphering population boundaries for species management purposes.

Another reason why the Banzai Mud Dauber Cave populations may be distinct from the Edwards Aquifer populations is that isopods in this cave may be limited by a biological or environmental factor such as food resources, inhospitable intermediate habitat, or competition with other deeper fauna. Or, given the invasion of this cave was recent and from a Trinity Aquifer population that was isolated since the Miocene from The Balcones Fault zone, evolution of sexual isolating mechanisms could have occurred. Any of these factors may limit the distribution of these Trinity isopods to near surface sites like Banzai Mud Dauber Cave and keep them from mixing with deep aquifer populations that communicate with downgradient sites including Comal Springs and San Marcos Springs.

A recent study places Texas populations in the subspecies *Cirolanides texensis texensis* and Mexican populations (including those of Cueva de El Tule, Cueva de la Espantosa and Sótano de Amezcuca) in *C. t. mexicensis* (Botosaneanu and Iliffe 2002), demonstrating that morphological characters can be used to differentiate these populations. The hydrogeologic hypothesis created herein also divided Texas and Mexico sites (Figure 2). The gene tree, however, indicates that Texas populations are not monophyletic with respect to Mexican ones. Mexico populations are paraphyletic and nested within Texas populations (Figures 8 and 9). Parametric bootstrapping was used to test the null hypothesis that Texas is monophyletic, and it was found that this cannot be rejected ( $p < 0.07$ ). This demonstrates that even though the Mexican populations fit



within the Edwards-Trinity Aquifer clade in the best gene tree (populations TU, EP and AM in Figure 8), there is a way to force the division of populations according to what side of the Rio Grande they are on. Low non-parametric bootstrap and Bayesian posterior probability values (13/74) for the node attaching Cueva de El Tule and Cueva de la Espantosa indicates this branch may have an alternate placement that aligns it with the other Mexican population, and therefore would be potentially more concordant with the morphological boundaries. The placement of Edwards Aquifer and Phantom Lake Cave populations in the gene tree indicate that they may also show morphological differences when examined more carefully.

On the basis of hydrogeological data, three populations north of Del Rio were predicted to cluster together; Dandridge Spring Cave, H.T. Miers Cave, and Four Mile Cave (see Figure 2). The gene data align Dandridge Spring Cave and H.T. Miers Cave, but not Four Mile Cave (see Figures 11 and 14). The null hypothesis that placed these three populations in monophyly was rejected ( $p < 0.01$ ). Although there is no known hydrogeologic barrier that would isolate Four Mile Cave, one possible explanation is that the Devil's River influences a subtle groundwater divide between Four Mile Cave and the Dandridge Spring Cave and H.T. Miers Cave group, keeping the systems that discharge into the Devil's River distinct from those that discharge at San Felipe Springs.

In one scenario, Sótano de Amezcuca, south of the Rio Grande, was also predicted to be in the Del Rio cluster (see Figure 2). The gene data do not support this alignment (see Figure 11). The null hypothesis placing Dandridge Spring Cave and H.T. Miers Cave with Sótano de Amezcuca (Table 2) was rejected ( $p < 0.03$ ). Here the genetic data support the hydrogeologic evidence of the Rio Grande as a drainage divide between Texas and Mexico localities.

A final bootstrapping test performed with the *Cirolanides* data rejected the null hypothesis of monophyly of Edwards-Trinity Aquifer caves ( $p < 0.01$ ). This is not surprising considering that both the Trinity Aquifer and Mexican populations were nested among Edwards-Trinity Aquifer populations in the best gene tree. This finding is significant because it emphasizes that the Trinity Aquifer populations, although distinguishable from Edwards-Trinity Aquifer populations, are not genetically distant. Mexican populations clustering within west Texas populations indicates that the separation between Phantom Lake Cave and the other west Texas populations is greater than that between the Mexico and west Texas populations. Although these results do not necessarily point to current gene flow among the Trinity Aquifer, Mexican and Edwards-Trinity Aquifer populations, their affiliations are relevant when considering hydrologic and conservation problems in these areas.

Some unexpected *Cirolanides* relationships that were not tested using parametric bootstrapping include the populations around the Pecos

River. It was expected that the Pecos River would be a prominent divide, differentiating North Canyon Spring (IN in Figure 14) from Edwards-Trinity sites east of the Pecos River. As in the case with the unexpected division between Dandridge/H.T. Miers group and Four Mile Cave, one possible hypothesis is that there is a subtle drainage divide between Sorcerer's Cave and North Canyon Spring, since Sorcerer's Cave discharges south to the Rio Grande and North Canyon Spring discharges east to the Pecos River via Independence Creek. Also the North Canyon Spring may be more closely related to Edwards-Trinity sites east of the Pecos River because the Pecos River does not completely bisect the Edwards Limestone in that area, as evidenced by the exposure of the top of the 50 to 100 meter deep Fort Terrett Member of the Edwards Limestone on either side of the Pecos River (Barnes 1981). Another possibility is that historically the Pecos River meandered west of North Canyon Spring.

Some surprises were also found in the *Lirceolus* dataset. Knee Deep Cave and Preserve Cave, sites that are near one another in the Cow Creek Limestone and that drain into the south side of the Guadalupe River, aligned with two different clades (and species) and the null hypothesis of monophyly was rejected (Table 2,  $p < 0.01$ ). Additionally, the null hypothesis that all of the Guadalupe River populations (Knee Deep Cave, Preserve Cave, Jacob's Well, Rattlesnake Cave) are monophyletic was rejected ( $p < 0.01$ ). Preserve Cave is the population that is not

clustering with the otherwise highly supported Guadalupe River basin clade (see Figures 13 and 15).

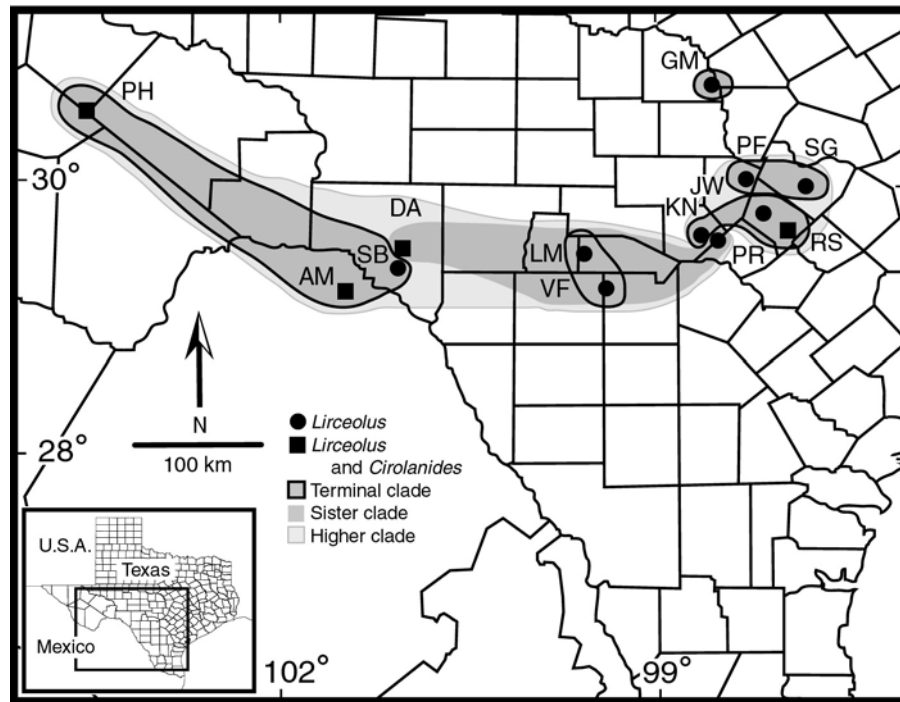

Fig. 15. Map showing genetic relationships of *Lirceolus* localities. Note that Preserve Cave (PR) is not most closely related to the nearby Cow Creek Limestone site, Knee Deep Cave (KN), nor does it cluster with the other Guadalupe River sites (KN, JW, RS). Also two sites in the Edwards Aquifer, Rattlesnake Cave and Sunken Gardens Spring (RS and SG), aligned with surface rivers rather than subterranean hydrogeology.

One possible explanation for this is that *Lirceolus pilus*, which is currently only known from the Nueces River basin, also occurs in the Cibolo Creek basin where little sampling has been done, and has been transported across the drainage divide to the Guadalupe River via subterranean connections (Veni 1997b) to Preserve Cave. Such

subterranean piracy of Cibolo Creek into the Guadalupe is congruent with the distribution of the cave adapted salamander *Eurycea tridentifera* (Chippindale et al. 2000). If this were true, *Lirceolus pilus* could have migrated from Cibolo Creek through Honey Creek Cave (where they are not known from but where sampling has been minimal), out of the spring resurgence at Honey Creek Cave, down Honey Creek, and up into Preserve Cave which is on the opposite (east) side of the surface creek. Migration in these smaller streams may be more feasible than migration in large rivers such as the Guadalupe since floods in them would be principally from springs and thus have more favorable physiochemical properties and fewer predators than would be found in floods in large rivers. *Lirceolus pilus* could also have invaded groundwater in the current Preserve Cave drainage basin, east of Honey Creek, prior to exposure of the resurgence to Honey Creek Cave when the cave extended east of Honey Creek (Veni 1997b). In either scenario, this shows that *Lirceolus* phylogenetics, though generally aligned with surface rivers, can also be influenced by subterranean connectivity. More sampling of these two basins may tease apart the history that led to the anomalous Preserve Cave population.

Another *Lirceolus* relationship incongruent with subterranean hydrology is paraphyly of Rattlesnake Cave and Sunken Gardens Spring; both sites in the Edwards Aquifer (see Figure 11). A null hypothesis forcing these two populations into a monophyletic group was rejected

( $p < 0.01$ ). Although it is possible that the groundwater divide between San Marcos Springs and Barton Springs permits subterranean migration, it is also possible that genetic structure in this genus is more strongly influenced by surface river basin relationships than by subsurface hydrogeology, as indicated in the likelihood and TreeMap analyses discussed above. Similarly, the null hypothesis of monophyly of all Edwards-Trinity Aquifer populations was rejected ( $p < 0.01$ ). Although divisions within the Edwards-Trinity Aquifer could be due to a groundwater divide over the large unsampled geographic area between *Lirceolus pilus* and *Lirceolus cocytus* populations, this pattern again seems better explained by greater affinity of this genus to surface rivers rather than subsurface drainages.

#### **THE RIO GRANDE AS A BARRIER: IS MEXICO PART OF THE EDWARDS-TRINITY AQUIFER?**

As shown in the *Cirolanides* gene tree (Figure 11), the Rio Grande did not fall out as the greatest barrier to gene flow, as predicted by hydrogeology. Two of the parametric bootstrapping tests, however, do clearly support divisions of populations on either side of the river. The scenario inferred from the gene tree is that the Mexican populations (Sótano de Amezcuca, Cueva de la Espantosa and Cueva de El Tule) are nested within west Texas localities, indicating that other barriers, such as the Balcones Fault Zone to the east, and an unidentified barrier west of the Pecos River, are older. This indicates that some among aquifer populations are more closely related than within aquifer populations (e.g.

northern Mexico populations are more closely related to most in the Edwards-Trinity Aquifer than some populations within the Edwards-Trinity Aquifer are to each other). Aquifer maps depict the Rio Grande as the southern limit of the Edwards-Trinity Aquifer, indicating a major boundary, but some studies found hydrogeologic evidence for water transport from Texas to Mexico (Rodriguez and Hendrickson 1998; Rodriguez and Berlanga 1992). This study does not address the hydrogeologic evidence of those possibilities, but clearly modern communication of *Cirolanides* isopods across the border is not supported. *Lirceolus* isopods were only found in one locality so the gene topology of their divergence from Texas populations could not be evaluated.

An unidentified barrier to the west of the Pecos River has maintained the isolation of Phantom Lake Cave, the deepest node in the *Cirolanides* tree after the Balcones Faulting. This was unexpected and may be influenced by the buried sections of the Edwards-Trinity between two of the Trans-Pecos sites (North Canyon Spring and Sorcerer's Cave) and the farthest west site, Phantom Lake Cave. Significant burial of karst could create discontinuous subterranean habitat if the burial prevents downward water movement, and therefore energy flow, such as with clay-rich alluvial deposits. In addition to preventing energy flow, these deposits may fill voids that could have supported populations intermediate to those in question. The issue of burial has been addressed with other cave species in Texas (Veni, in prep.).

## COMPARISON TO RELATIONSHIPS OF OTHER AQUATIC TAXA

Relationships of one other freshwater cave and spring dwelling taxon, the plethodontid salamander genus *Eurycea*, has been examined extensively in Texas across the Edwards Limestone (Chippindale et al. 2000). Although there are not enough shared localities to make a meaningful statistical comparison, anecdotal comparisons are possible.

Chippindale et al. (2000) describe four main clades. The southwestern group is the *Eurycea troglodytes* complex and is located in the western and southern edge of the Balcones Escarpment and includes primarily Bandera, Edwards, Gillespie, Kerr, Medina, Real and Uvalde counties. The southeast group is *Eurycea sosorum*, *E. pterophila*, *E. neotenes*, *E. tridentifera* and the *E. latitans* complex. This group occurs on the southeast part of the Balcones Escarpment and includes primarily Bexar, Blanco, Comal, Hays, Kendall and Travis counties, except for the area around San Marcos. The San Marcos group consists of *E. nana* and *E. rathbuni* which are distributed immediately adjacent to San Marcos.

In the *Lirceolus* phylogeny, geographic distribution of the Lost Maples State Park Spring and Valdina Farms Sinkhole clade (LM+VF), or *Lirceolus pilus*, matches the distribution of the *Eurycea troglodytes*, or southwestern group. The type locality for *E. troglodytes* is the isopod locality VF and the Sabinal Springs population for the salamander is along the same river, within a kilometer of the isopod locality LM. However, in the isopod phylogeny, Preserve Cave is in the LM+VF clade though the



map of *Eurycea* localities (Chippindale et al. 2000) indicates that the Preserve Cave population would probably contain individuals from the southeast clade. The southeast clade of salamanders corresponds to isopod localities such as Sunken Gardens, Pedernales Falls Spring, Knee Deep Cave and Jacob's Well, or the *Lirceolus hardeni* clade. The newly discovered *Eurycea* specimens from Preserve Cave are yet to be placed in the phylogenetic tree, so no definitive conclusions about this congruence can be made.

Excluding the unanalyzed Preserve Cave population and the San Marcos *Eurycea* and *Lirceolus* population at Rattlesnake Cave, the isopod clade corresponding to *Lirceolus hardeni* roughly corresponds to the southeast clade for *Eurycea*. The excluded population (Rattlesnake Cave), however, is at the end of a deep split in the *Eurycea* tree and it is a terminal node in the *Lirceolus* tree.

The *Cirolanides* phylogeny appears congruent with three clades of the *Eurycea* phylogeny, including one with two Edwards Aquifer populations (Ezell's Cave and Rattlesnake Cave which correspond to *E. rathbuni*), one with several populations in the Trinity Aquifer (Bufo Cave, Klar Well, Honey Creek Cave and Banzai Mud Dauber Cave which correspond roughly to the southeast *Eurycea* clade) and one with an isopod population, Devil's Sinkhole, that corresponds to the southwest *Eurycea* clade. Excluding two populations, Isopit (corresponds to *E. neotenes*), and Panther Canyon Well (Comal Springs), the relationship of

these three clades is congruent, with the deepest split at the Ezell's/Rattlesnake clade, and the ingroup consisting of the southeast and southwest clades.

Congruence may also be expected with patterns of species breaks in the freshwater fish fauna of Texas, and these have been analyzed using a faunal resemblance index (Conner and Suttkus 1986). This index was transformed into a faunal similarity matrix for rivers across Texas, with three of those rivers overlapping the current study area. The pattern of faunal similarity for those three rivers groups the San Antonio and Nueces rivers, with the Colorado River as an outgroup to them. Since the *Cirolanides* tree did not match surface rivers at all, a comparison is not warranted. The *Lirceolus* tree had several clades that matched river drainages, but because both Colorado and Guadalupe River populations occurred in two different places in the tree no conclusions can be made.

#### **CONSERVATION IMPLICATIONS**

Many species in Texas rely directly on aquifer, spring, and downstream water quality and quantity. Already there are documented extinctions of several spring-dwelling vertebrates and invertebrates as a result of spring drying (Brune 1981). Groundwater pumping continues to expand unchecked due to a lack of understanding of sustainable yield, and outdated "right of capture" laws in place over most of the area (Sharp 1998). Additionally, aquifer quality has been affected by human activities.

Patterns of population relatedness, such as revealed in this study, are important for establishing geographic management units for these species. For example in the Cirolanidae, the Edwards Aquifer sites Ezell's Cave, Panther Canyon Well and Rattlesnake Cave form a unique group that should be treated separately from nearby Trinity Aquifer sites in terms of potential future conservation actions (e.g. mitigation, captive breeding, etc.). Other unique phylogenetic groups in that family include Sorcerer's Cave, Dandridge Spring Cave and H.T. Miers Cave, the Mexican sites Cueva de El Tule and Cueva de la Espantosa as well as Sótano de Amezcua, and the far west Texas site Phantom Lake Cave (SR, DA, HT, TU, ES, AM, PH in Figure 14). Considering that the Mexican localities were found to have morphological variation sufficient to describe a subspecies (Botosaneanu and Iliffe 2002), it may be worth examining the far west Texas site (Phantom Lake Cave) and the Edwards Aquifer sites that are more genetically distant than Mexican populations for morphologies that may warrant splitting into new species.

Unique subdivisions in the *Lirceolus* include the group consisting of primarily *Lirceolus cocytus* localities (Sótano de Amezcua, Slaughter Bend Springs, Phantom Lake Cave; AM, SB and PH in Figure 15), the group consisting of some *Lirceolus pilus* localities (Dandridge Spring Cave, Lost Maples State Park Spring, Valdina Farms Sinkhole and Preserve Cave; DA, LM, VF and PR in Figure 15), the group consisting of primarily *Lirceolus hardeni* localities (Jacob's Well, Rattlesnake Cave, Knee Deep

Cave, Pedernales Falls Spring and Sunken Gardens Spring; JW, RS, KN, PF and SG in Figure 15), and the *Lirceolus bisetus* site (Gorman Cave; GM in Figure 15). The species that stands out as most rare in this group is *L. bisetus*, though it is also known from Barton Springs. Individuals collected from Barton Springs (Sunken Gardens) during this study were not examined by a taxonomic expert to verify their identity as *L. bisetus* or *L. hardeni* prior to sequencing, but reports indicate that *L. hardeni* is more common there.

The patterns found for these two isopod groups demonstrate that known hydrogeologic relationships may not perfectly predict organismal gene flow (past or present), and relationships of other groundwater-dwelling taxa may not exactly match taxa studied here. Both habitat ecology and hydrogeologic history clearly played a role in determining phylogenetic relationships of these two isopods, and all of these aspects must be understood in order to create efficient conservation strategies.

## Appendix I

The column headers in this appendix are as follows. The site name is given in its entirety, with alternate or more specific names given in parentheses. All counties are Texas counties, unless specified as Mexican states. Due to the sensitive nature of cave locations, specific location information on all of the sites is not provided here. The majority of cave locations, landowner contact information, and cave maps were borrowed from the Texas Speleological Survey, a repository for cave data for the state of Texas, and most of the locations and associated information may be borrowed from the Texas Speleological Survey (<http://www.txspeleologicalsurvey.org>). The taxon collected from each locality, and the individual specimen identification numbers (JKK ID) are given in the next two columns. The two-letter site codes used in some of the figures corresponds to the specimen identification numbers (JKK ID). The final two columns show the GenBank accession numbers for the mitochondrial 16S and CO1 genes.

Cave name	County	Taxon	JKK ID	16S	CO1
Barton Springs (Sunken Gardens)	Travis	<i>Lirceolus hardeni</i>	SG92	AY570135	AY566549
		<i>L. hardeni</i>	SG93	AY570136	AY566552
		<i>L. hardeni</i>	SG3	AY570137	AY566550
		<i>L. hardeni</i>	SG4	AY570138	AY566551
Bear Spring	Bell	<i>Caecidotea reddelli</i>	BR62	----	AY566522
Banzai Mud Dauber Cave	Bexar	<i>Cirolanides texensis</i>	BM65	AY570069	AY566484
		<i>C. texensis</i>	BM66	AY570070	AY566485
Boxed Spring	Kerr	<i>C. texensis</i>	BX21	AY570073	AY566488
		<i>C. texensis</i>	BX22	AY570074	AY566489
Bufo Cave	Kendall	<i>C. texensis</i>	BU23	AY570071	AY566486
		<i>C. texensis</i>	BU24	AY570072	AY566487
Cave Y (Whitten Cave)	Schleicher	<i>C. texensis</i>	CY15	AY570075	AY566490
		<i>C. texensis</i>	CY16	AY570076	AY566491
Cueva de Jacobo	Coahuila, Mexico	<i>Speocirolana thomydronis</i>	JA55	AY570144	AY566526
		<i>Sphaerolana interstitialis</i>	JA56	AY570145	----
		<i>Sphaerolana interstitialis</i>	JA63	AY570146	----
Cueva de la Espantosa	Nuevo Leon, Mexico	<i>C. texensis</i>	EP41	AY570081	AY566494
		<i>C. texensis</i>	EP42	AY570082	AY566495
Cueva de El Tule	Nuevo Leon, Mexico	<i>C. texensis</i>	TU43	AY570111	AY566520
		<i>C. texensis</i>	TU44	AY570112	AY566521
Dandridge Spring Cave	Val Verde	<i>C. texensis</i>	DA25	AY570077	AY566492
		<i>C. texensis</i>	DA26	AY570078	AY566493
		<i>L. sp.</i>	DA77	AY570115	AY566529
		<i>L. sp.</i>	DA78	AY570116	AY566530
Devil's Sinkhole	Edwards	<i>C. texensis</i>	DS104	AY570079	AY566470
		<i>C. texensis</i>	DS105	AY570080	AY566471
Emerald Sink	Val Verde	<i>Speocirolana hardeni</i>	EC47	AY570141	AY566524
			EC48	AY570142	AY566525

Cave name	County	Taxon	JKK ID	16S	CO1
Ezell's Cave	Hays	<i>C. texensis</i>	EZ33	AY570083	AY566500
		<i>C. texensis</i>	EZ34	AY570084	AY566496
		<i>C. texensis</i>	EZ89	AY570085	AY566499
		<i>C. texensis</i>	EZ90	AY570086	AY566497
		<i>C. texensis</i>	EZ91	AY570087	AY566498
Four Mile Cave	Val Verde	<i>C. texensis</i>	FM27	AY570088	AY566501
		<i>C. texensis</i>	FM28	AY570089	AY566502
Gorman Cave	San Saba	<i>L. bisetus</i>	GM73	AY570117	AY566532
		<i>L. bisetus</i>	GM74	AY570118	AY566533
		<i>L. bisetus</i>	GM1	----	AY566531
H.T. Miers Cave	Val Verde	<i>C. texensis</i>	HT106	AY570093	AY566473
		<i>C. texensis</i>	HT107	AY570094	AY566474
Honey Creek Water Cave	Comal and Kendall	<i>C. texensis</i>	HC94	AY570090	AY566503
		<i>C. texensis</i>	HC95	AY570091	AY566504
		<i>C. texensis</i>	HC96	AY570092	AY566505
Isopit	Bexar	<i>C. texensis</i>	IS17	AY570095	AY566506
		<i>C. texensis</i>	IS18	AY570096	AY566507
Jacob's Well	Hays	<i>L. hardeni</i>	JW97	AY570119	AY566534
		<i>L. hardeni</i>	JW98	AY570120	AY566535
Klar Well	Comal	<i>C. texensis</i>	KL35	AY570097	AY566508
		<i>C. texensis</i>	KL36	AY570098	AY566509
Knee Deep Cave	Kendall	<i>L. hardeni</i>	KN13	AY570121	AY566536
		<i>L. hardeni</i>	KN100	AY570122	AY566537
		<i>L. hardeni</i>	KN99	AY570123	----
Lost Maples State Park Spring	Bandera	<i>L. pilus</i>	LM79	AY570124	AY566538
		<i>L. pilus</i>	LM80	AY570125	AY566539
O-9 Well	Crockett	<i>C. texensis</i>	O9101	AY570099	AY566477
		<i>C. texensis</i>	O9102	AY570100	AY566476
Ojo Encantado	Tamaulipas Mexico	<i>Speocirolana</i> sp.	OE52	AY570148	----
Panther Canyon Well (Landa Park Well)	Comal	<i>C. texensis</i>	PA37	AY570101	AY566510
		<i>C. texensis</i>	PA38	AY570102	AY566511
Pedernales Falls Spring	Blanco	<i>L. hardeni</i>	PF9	AY570126	AY566540
		<i>L. hardeni</i>	PF10	AY570127	AY566541

Cave name	County	Taxon	JKK ID	16S	CO1
Phantom Lake Spring Cave	Jeff Davis	<i>C. texensis</i>	PH39	AY570103	AY566512
		<i>C. texensis</i>	PH40	AY570104	AY566513
		<i>L. cocytus</i>	PH81	AY570128	AY566542
		<i>L. cocytus</i>	PH82	AY570129	AY566543
		<i>L. cocytus</i>	PH83	AY570130	AY566544
Preserve Cave	Comal	<i>L. probably pilus</i> - new locality	PR49	AY570131	AY566545
		<i>L. probably pilus</i> - new locality	PR57	AY570132	AY566546
Rattlesnake Cave	Hays	<i>C. texensis</i>	RS7	AY570105	AY566515
		<i>C. texensis</i>	RS103	AY570106	AY566514
		<i>L. probably hardeni</i> - new locality	RS19	AY570133	AY566547
		<i>L. probably hardeni</i> - new locality	RS72	AY570134	AY566548
Santa Tecla	Coahuila, Mexico	<i>Sphaerolana affinis</i>	TE84	AY570109	AY566518
		<i>S. affinis</i>	TE85	AY570110	AY566519
Slaughter Bend Springs (Indian Springs, highest elevation outlet)	Val Verde	<i>L. probably cocytus</i> - new locality	SB110	AY570150	AY566480
		<i>L. probably cocytus</i> - new locality	SB111	AY570151	AY566479
Sorcerer's Cave	Terrell	<i>C. texensis</i>	SR5	AY570107	AY566516
		<i>C. texensis</i>	SR6	AY570108	AY566517
Sótano de Amezcuca	Coahuila, Mexico	<i>C. texensis</i>	AM86	AY570066	AY566481
		<i>C. texensis</i>	AM87	AY570067	AY566482
		<i>C. texensis</i>	AM88	AY570068	AY566483
		<i>L. cocytus</i>	AM68	AY570113	AY566527
		<i>L. cocytus</i>	AM69	AY570114	AY566528



Cave name	County	Taxon	JKK ID	16S	CO1
Spring outflow of North Canyon, Independence Creek Tributary (called North Canyon Spring herein, also known as Isopod Spring)	Terrell	<i>C. texensis</i>	IN109	----	AY566475
Valdina Farms Sinkhole	Medina	<i>L. pilus</i>	VF50	AY570139	AY566553
		<i>L. pilus</i>	VF59	AY570140	AY566554

## Appendix II

Physical descriptions of collecting localities tabulated in Appendix I are given below. The names are given in the same order as in Appendix I, where county data are given and locality information is discussed.

Barton Springs (Sunken Gardens): Barton Springs is a complex of spring openings on Barton Creek, and the spring opening sampled in this study is Sunken Gardens. At Sunken Gardens there is an area approximately two square meters where water boils up through sand and rocks, approximately 3.3 meters deep. The water is pooled to this depth because a concrete wall is built around the spring. *Lirceolus hardeni* were found on the undersides of sticks in dark areas of the pool. They were collected with the aid of SCUBA. *Eurycea* salamanders were also observed in this pool.

Bear Spring: Bear Spring consists of two primary outlets on a hillside. The water from these outlets is approximately 0.1 meters deep and up to a meter wide, where it runs over rocks and through some narrow concrete channels to a concrete holding pool. The two spring runs join each other before going into the holding pool. *Caecidotea reddelli* were found underneath rocks in the spring runs upstream of the holding pool, and collected by hand.

Banzai Mud Dauber Cave: This cave is primarily vertical, with a series of pits connected by very short passages. The total depth is 37

meters. A map, complete physical description of the cave, and information on biology, history, geology and paleontology is given in Veni et al. (1996). *Cirolanides texensis* were found in the water crawl at the bottom of the cave and collected by hand.

Boxed Spring: This spring originates from an small hole in bedrock, and is covered by a concrete box where water is pooled to a depth of less than 0.5 meters for delivery to pipes. The floor of the box is covered with rocks and silt, *Cirolanides texensis* were found swimming in the water column and under rocks. They were collected by hand.

Bufo Cave: Bufo Cave is a short entrance crawl followed by an eight meter deep pit. At the bottom of the pit a breakdown pile slopes to a very small crawlway with pooled water. The total surveyed depth of the cave is 10.5 meters. The map and cave location are available through the Texas Speleological Survey. *Cirolanides texensis* were found in the pool near the bottom of the pit, and were collected by hand.

Cave Y: Cave Y is also known as Whitten Cave. The entrance to this cave was modified with concrete to accept a manhole cover as a gate. The entrance is the top of a 15 meter vertical drop, which leads to a series of rooms, crawlways and pits before accessing a small stream. Elliott (1994b) describes the cave and gives a bibliography, and a complete description and cave location are available through the Texas Speleological Survey. *Cirolanides texensis* were found in the cobble

floored stream passage in less than 0.5 meters of water. They were collected by hand.

Cueva de Jacobo: This cave was named during this study after Jacob Hendrickson who first explored the site. The cave is located in the Cuatro Ciénegas basin. This site was not previously known to contain fauna. The cave has a vertical entrance about three to four meters deep that intersects a joint seven meters long and one to two meters wide, the floor of which is covered with water and mud. At either end of the joint the water deepens to 0.3 meters where *Speocirolana thomydronis* and *Sphaerolana interstitialis* were collected by hand. The water in the pools was flowing and seems to be connected to a more extensive unenterable stream.

Cueva de la Espantosa: This cave is located north of the town of Bustamante on the Rancho Cerro Colorado. The entrance is at the bottom of a cliff face with a slope of talus below the entrance. The cave has a series of rooms and passages which can be followed for less than 100 meters to a silt floored sump pool. *Cirolanides texensis* were collected by hand in the sump pool.

Cueva de El Tule: This cave is located north of the town of Bustamante on the Rancho Cerro Colorado. It has a spring entrance, and the cave stream can be followed less than 50 meters back to a sump pool. *Cirolanides texensis* were collected by hand in the sump pool on bedrock

walls and silt floor and in the stream on flowstone and cobbles immediately downstream of the pool.

Dandridge Spring Cave: This cave has a natural spring entrance and a blasted entrance that intersects the passage approximately two meters into the cave. The spring entrance and passage average a meter or less in diameter, with water filling at least half of the passage. The surveyed length of the single passage is 32 meters. A complete physical description of the cave, the map, and cave location are available through the Texas Speleological Survey. This site was not previously known to contain fauna. *Cirolanides texensis*, *Lirceolus* sp., and amphipods were captured by hand under rocks in the cobble floored passage, and in large nets placed over the opening while cavers disturbed the substrate upstream of the nets.

Devil's Sinkhole: The Devil's Sinkhole has a large, vertical entrance leading to a breakdown cone. At two places along the perimeter of the breakdown cone there are pools of water with a breakdown bottom, sloping out of sight. The surveyed length of the cave is 329 meters and depth is 107 meters. Veni (1994d) provides a description, map and bibliography, and the cave location is available through the Texas Speleological Survey. *Cirolanides texensis* were captured by hand in the water column and on rocks in pool. *Stygobromus hadenoecus* amphipods were also collected.

Emerald Sink: A sinkhole entrance leads to a series of rooms, crawls, and pits that end at a silt-bottomed sump pool. The floor of this sump pool slopes out of sight. Elliott and Reddell (1994a) give a physical description of the cave, a map, and some biological observations and the cave location is available through the Texas Speleological Survey. *Speocirolana hardeni* isopods and *Holsingerius smaragdinus* amphipods were captured by hand in the water column and on the silt floor in the shallow areas of the sump pool.

Ezell's Cave: The sinkhole entrance leads to a small shelf that drops into an entrance room. From here the passage continues steeply along the wall of a breakdown slope until reaching water table level. The underwater passage continues down at this steep angle to at least 20 meters of depth below the water table. The surveyed length of the cave is 76 meters, the depth is 15 meters (to water level) and a description of the cave, map, notes on the biology and bibliography are given by Cradit and Cradit (1994). The cave location is available through the Texas Speleological Survey. *Cirolanides texensis* were captured by hand in the water column, on silt and rock substrates, and with the assistance of bait. They were collected with the aid of SCUBA. *Eurycea* salamanders, shrimp, and a variety of other invertebrates were also observed in this pool.

Four Mile Cave: Also known as Sally Cave, the main level of passages is a maze that is accessed by one of two climbable pit

entrances to the cave. Within the maze of passages, there are several intersections with vertical pits that extend to pooled water. The surveyed length is 1,555 meters and the depth is 23 meters. A description of the cave, map, and cave location are given by Elliott and Reddell (1994b). The cave location is available through the Texas Speleological Survey. *Cirolanides texensis* were captured in bottle traps placed in a pool approximately one meter in diameter and 1.5 meters deep, with bedrock walls and rock and gravel floor. *Eurycea* salamanders were collected in the same pool.

Gorman Cave: This cave entrance is a spring, and continues as a single, large (up to ten meters high) passage with an intermittent stream and pools. The cave is not commercial but can be toured with permission from Texas Parks and Wildlife, therefore it is frequently visited. The surveyed length is 914 meters with eight meters of vertical change. A description of the cave, map, and bibliography is given by Elliott (1994a). The cave location is available through the Texas Speleological Survey. *Lirceolus bisetus* were collected by hand off of sticks in a small, gravel bottomed stream pool less than 0.5 meters deep located between Separation Lake and Swiss Cheese, features indicated on the cave map.

H.T. Miers Cave: This cave has a series of vertical drops that lead to horizontal passage, including one section containing a small stream that is pooled in places up to one meter wide and one meter deep. The surveyed length is 1,122 meters and depth is 103 meters. A description of

the cave, simplified map and bibliography is given by Napper (1994). The cave location, detailed map and more descriptions are available through the Texas Speleological Survey. *Cirolanides texensis* were seen in the stream passage which extends off of the south end of the Big Room (stream passage is not shown on the map). They were collected by hand in the water column and on the bedrock walls and rock and gravel substrates of the stream pools.

Honey Creek Water Cave: The longest cave in Texas, this cave is known for extensive stream passage, internal drainage divides, an artificial drilled entrance upstream in the cave, and a natural spring entrance from which the cave was discovered. The surveyed length is 32,101 meters, and vertical extent is 37.9 meters. A description of the cave, simplified map and bibliography is given by Veni (1994c). The cave location, detailed map and more descriptions are available through the Texas Speleological Survey. Isopods were not seen in the main passage, probably because of the deep water which makes them difficult to spot. *Eurycea* salamanders were seen in the main passage. *Cirolanides texensis* were collected by hand in the “R Survey” section of the cave as they swam through the water column.

Isopit: This cave has a small entrance opening (approximately 0.5 meters in diameter) which can be climbed down to a series of pits descending approximately 20 meters to a stream passage. The surveyed length is 417 meters, and vertical extent is 35 meters. A map and other



details of the cave can be found in Veni (1997a). The cave location is available through the Texas Speleological Survey. *Cirolanides texensis* were collected by hand in the stream passage that was less than 0.1 meters deep and one meter wide with a cobble floor.

Jacob's Well: This is a natural spring opening in the bottom of a creek. The opening is approximately one meter under water and the entrance shaft, which is 4 meters wide, descends about ten meters to another offset shaft. The passage continues past two squeezes upstream at depths of up to 43 meters. The cave location, map, descriptions and bibliography are available through the Texas Speleological Survey. This site was not previously known to contain fauna. *Lirceolus hardeni* were collected by hand off of sticks at the bottom of the second shaft, using SCUBA between 15 and 20 meters deep. *Eurycea* salamanders were also collected.

Klar Well: This is a drilled well that is 51 meters deep and 0.15 meters in diameter. The well log suggests that the fauna are probably falling into the well from a conduit with perched water that is intersected by the well bore, rather than coming in from deep in the when where no conduits are apparent in the log. Veni (1997b) provides a complete description of the site. *Cirolanides texensis* were collected in a baited trap that was left for 48 hours.

Knee Deep Cave: The entrance to this cave is a spring on a small bluff. The single passage averages 1.5 meters wide by 0.5 meters tall and

is typically half full of water. The surveyed length is 251.7 meters. The cave location, map, descriptions and bibliography are available through the Texas Speleological Survey. *Lirceolus hardeni* were collected by hand off of the bottom of rocks on the floor of the passage.

Lost Maples State Park Spring: This is a spring opening less than 0.2 meters in diameter in the side of a valley. The spring was once used as a water supply and there are remains of a stock tank nearby. The spring immediately flows steeply down a bedrock wall to the main channel. The location is available through the Texas Speleological Survey. *Lirceolus pilus* were collected by hand off of the bottom of rocks at and just inside the spring orifice.

O-9 Well: This cave has a series of vertical drops and pools that lead in the downstream direction to a sump pool. The surveyed length is 1,372 meters, and vertical extent is 101 meters. Reddell et al. (1994) give a description of the cave, map, notes on biology and bibliography. The cave location and passage descriptions are available through the Texas Speleological Survey. *Cirolanides texensis* were collected in a baited wide mouth bottle placed in the sump pool.

Ojo Encantado: The entrance to this cave is a spring resurgence at the bottom of a deep canyon. Just inside the ten meter diameter entrance is a long, deep pool where isopods were collected by hand as they swam through the water column. This site was not previously known to contain fauna. The cave can be followed upstream for at least 100 meters. The

cave is mentioned in Hendrickson et al. (2001) as having isopods preliminarily identified as *Speocirolana pelaezi* and *S. bolivari* but no blind catfish.

Panther Canyon Well: Also known as Landa Park Well, this is a man made well, approximately 0.15 meters in diameter, with casing down to about 20 meters. This well has been traced to Comal Springs, with travel time from the well to Comal Springs in less than three hours (Schindel et al. 2005). The water level was about seven meters from the surface when this site was visited. This site was not previously known to contain fauna, but site managers using a downhole camera saw isopods and flatworms. A baited trap was set on the bottom of the well, approximately 20 meters deep. *Cirolanides texensis* isopods and *Stygobromus pecki* amphipods were caught in traps set for 24 to 48 hours.

Pedernales Falls Spring: This spring emerges from a wide, low opening several meters from a river. The spring location is available through the Texas Speleological Survey. *Lirceolus hardeni* were found clinging to the undersides of large (> 0.1 meters in diameter) rocks at and just inside the spring orifice. They were collected by hand.

Phantom Lake Spring Cave: This spring emerges from the base of a small bluff, and is only enterable for a very short distance without SCUBA. The majority of the cave is underwater, with 2,575 meters of surveyed passage, 24 meters of vertical extent, and passage diameters of up to ten meters. This site is the type locality for *Lirceolus cocytus* (Lewis

2001) but was not previously known to contain other isopods or amphipods. The cave location, map, descriptions and bibliography are available through the Texas Speleological Survey. *Lirceolus cocytus* were collected by hand from submerged roots while using SCUBA. *Cirolanides texensis* were also collected by hand on bedrock walls and around a turtle carcass. A single stygobitic amphipod, preliminarily assigned to *Holsingerius* sp. (John Holsinger, pers. comm.), was also collected on a silt floor near the root masses where asellids were found.

Preserve Cave: A two meter entrance climbdown leads to a low, wide passage approximately 20 meters long before reaching a pool. The surveyed length is 1,086 meters, and vertical extent is 14.5 meters. During high water events, the entrance becomes a spring. This site was not previously known to contain aquatic fauna. The cave location and descriptions are available through the Texas Speleological Survey. In the first pool, and in several small (< 0.05 meters in diameter) water filled depressions in the clay before the pool, *Lirceolus* sp. isopods were collected. They were not examined morphologically, but are presumed to be *L. pilus* because of their location on the gene tree (see Figure 10). *Eurycea* salamanders were also collected in the first pool.

Rattlesnake Cave: A one meter diameter entrance leads steeply down approximately 6 meters to a sump pool. The pool is 0.5 meters wide, one meter long and less than one meter deep in the center. At the corners of the bottom of the pool, passage continues downward out of

sight. A map and description of the cave is given by Russell (1976). The cave location is available through the Texas Speleological Survey. During most visits to this site, *Eurycea* salamanders were seen in the pool. On one occasion the water was extremely low (exposing part of the normal pool bottom to the surface), no salamanders were seen, but *Lirceolus* sp. isopods were abundant on rocks on the bottom of the pool and collected by hand. These specimens were not morphologically examined, but prior collections from here were preliminarily identified as *Lirceolus* sp. nr. *pilus*. Collections from this study clustered genetically with *Lirceolus hardeni* (see Figure 10). *Cirolanides texensis* were not previously known from this site, but were discovered in baited bottle traps.

Santa Tecla: This site is in the Cuatro Ciénegas basin and the area has at least four spring outlets, and is sometimes called La Sauza or Antiguas Mineras del Norte. One of the spring outlets is a pool approximately two meters in diameter and one to 1.5 meters deep with a sediment bottom. The sediment roils where water resurges from the bottom. From the map in the species description, this is the type locality, or very close to the type locality, of *Sphaerolana affinis* (Cole and Minckley 1970). *Sphaerolana affinis* was found clinging to substrates including sticks and rocks. Another unidentified isopod, not previously recorded, was discovered clinging to sticks at this site. Isopods were collected by hand with the aid of a mask and snorkel.

Slaughter Bend Springs: This area has many springs, clustered in at least four areas, each area with up to three separate spring orifices. The spring locations are available through the Texas Speleological Survey. One of the areas is known as Indian Springs, and it is at the highest outlet of Indian Springs where *Lirceolus* sp. isopods were collected in drift nets left at the outlet for two weeks. They were not examined morphologically, but are presumed to be *L. cocytus* because of their location on the gene tree (see Figure 10). This is a new record for asellid isopods at this locality.

Sorcerer's Cave: The deepest cave in Texas, this cave is a series of vertical drops and passages that lead to the Sirion River. The surveyed length is 3,510 meters, and vertical extent is 173.7 meters. A description of the cave, map, notes on biology, notes on archaeology, and a bibliography is given by Veni (1994f). *Cirolanides texensis* were collected by hand and with the assistance of bait in the bottom of the cave where water is first encountered at the bottom of the cave. Here the stream is less than 0.2 meters deep and less than 1 meter wide with cobble and flowstone substrate.

Sótano de Amezcuá: The entrance to this cave is in the bottom of a 20 meter deep sinkhole, and consists of a 70 meter vertical shaft leading into a large chamber where a stream passage is intersected. The surveyed length is 675 meters and the total depth is 83 meters. Hendrickson et al. (2001) discuss the *Prietella* blind catfish, isopods,

amphipods, and give a map and descriptions of the site. This site is the only Mexican locality for *Lirceolus cocytus*, which were found downstream of the entrance in 'BBB Lake' as indicated on the cave map. They were locally abundant and could be collected by hand off of a small pile of cricket or bat guano in a section of stream pool less than 0.1 meters deep and one to two meters wide. *Cirolanides texensis* were collected by hand from rocks and bedrock substrate in downstream sections of stream pool and in by hand while on SCUBA in upstream sections of submerged passage.

Spring outflow of North Canyon, Independence Creek Tributary (called North Canyon Spring in this document): This site is also known as Isopod Spring or McCurdy Spring. This spring flows (following periods of heavy rainfall only) out from amid large limestone cobbles at the base of a hillside along Independence Creek Road, just east of the mouth of the North Canyon of the Oasis Ranch. The exact spring location is available through the Texas Speleological Survey. The outflow flows along a relatively flat stream bed along and then across Independence Creek Road, and then into Independence Creek. This site was not previously known to contain aquatic fauna, until *Cirolanides texensis* were collected by hand by Robert McCurdy from the spring orifice.

Valdina Farms Sinkhole: This large sinkhole entrance has been altered with a man-made channel to accept stream flow from the nearby Seco Creek during floods. A series of entrance pits leads to a main level

that can be followed upstream and downstream. The surveyed length is 677 meters, and vertical extent is 57.9 meters. Veni (1994e) provides a description of the cave, history, some notes on biology and geology, and a bibliography. The cave location and other details are available through the Texas Speleological Survey. This site was previously known to contain *Cirolanides texensis*, but none were found. Their absence may be due to the extirpation of a large bat colony which provided energy to the system. *Eurycea* salamanders are also known to be extirpated from the cave due to the artificial recharge project. *Lirceolus pilus* were collected by hand off of rocks and leaf litter in the upstream portion of the cave, and may be the only remaining stygobite in the cave.



## Bibliography

- Ashworth, J. B. and J. Hopkins. 1995. Aquifers of Texas. Texas Water Development Board Report No. 345:1-69.
- Avise, J. C. and R. K. Selander. 1972. Evolutionary genetics of cave-dwelling fishes of the genus *Astyanax*. *Evolution* 26:1-19.
- Baratti, M., M. Bazzicalupo, C. DeFilippo, and G. Messana. 1999. Detection of genetic variability in stygobitic isopods using RAPD markers. *Crustaceana* 72:625-634.
- Barker, R. A. and A. F. Ardis. 1996. Hydrogeologic framework of the Edwards-Trinity Aquifer system, west-central Texas. U.S. Geological Survey Professional Paper 1421-B:1-61.
- Barnes, V. E. 1981. Geologic atlas of Texas, Sonora Sheet. Roy Thorpe Hazzard memorial edition. University of Texas-Austin, Bureau of Economic Geology. Scale 1:250,000.
- Berettoni, S., J. Mathieu, and F. Hervant. 1998. Genetic variation in the stygobite amphipod *Niphargus rhenorhodanensis*: Comparison of four hyporheic populations of the Rhône and the Ain Rivers (France). *Arch. Hydrobiol.* 142:485-492.
- Botosaneanu, L. and T. M. Iliffe. 2002. Notes on the intraspecific variability of *Cirolanides texensis* Benedict, 1896 (Isopoda: Cirolanidae) from Texas and Mexico. *Bulletin de L'Institut Royal des Sciences Naturelles de Belgique* 72:113-117.
- Botosaneanu, L., T. M. Iliffe, and D. A. Hendrickson. 1998. On a collection of stygobitic cirolanids (Isopoda: Cirolanidae) from northern Mexico, with description of a new species. *Bulletin de L'Institute Royal des Sciences Naturelles de Belgique, Biologie* 68:122-134.

- Bowman, T. E. 1964. *Antrolana lira*, a new genus and species of troglobitic cirolanid isopod from Madison Cave, Virginia. *International Journal of Speleology* 1:229-236.
- Bowman, T. E. and G. Longley. 1976. Redescription and assignment to the new genus *Lirceolus* of the Texas troglobitic water slater, *Asellus smithii* (Ulrich) (Crustacea: Isopoda: Asellidae). *Proceedings of the Biological Society of Washington* 88:489-496.
- Brune, G. 1981. Springs of Texas. Texas A&M University Press, College Station, Texas. Pages 1-566.
- Chippindale, P. T., A. H. Price, J. J. Wiens, and D. M. Hillis. 2000. Phylogenetic relationships and systematic revision of central Texas Hemidactyliine Plethodontid Salamanders. *Herpetological Monographs* 14:1-80.
- Cole, G. A. and W. L. Minckley. 1966. *Speocirolana thermydronis* a new species of cirolanid isopod crustacean from central Coahuila, México. *Tulane Studies in Zoology* 13:17-22.
- Cole, G. A. and W. L. Minckley. 1970. *Sphaerolana*, a new genus of cirolanid isopod from northern Mexico, with description of two species. *Southwestern Naturalist* 15(1):71-81.
- Conner, J. V. and R. D. Suttkus. 1986. Zoogeography of Freshwater Fishes of the Western Gulf Slope of North America. Pages 413-456 *in* C. H. Hocutt and E. O. Wiley, eds. *The Zoogeography of North American Freshwater Fishes*. John Wiley & Sons, New York.
- Cradit, J. and L. Cradit. 1994. Texas Wild Caves: Hays County: Ezell's Cave. Pages 212-213 *in* W. R. Elliott and G. Veni, eds. *The Caves and Karst of Texas*. The National Speleological Society, Huntsville, Alabama.
- Culver, D. C., T. C. Kane, and D. W. Fong. 1995. Adaptation and natural selection in caves: the evolution of *Gammarus minus*. Harvard University Press, Cambridge, Massachusetts. Pages 1-223.

- Elliott, W. R. 1994a. Texas Wild Caves: San Saba County: Gorman Cave. Pages 252-253 in W. R. Elliott and G. Veni, eds. The Caves and Karst of Texas. The National Speleological Society, Huntsville, Alabama.
- Elliott, W. R. 1994b. Texas Wild Caves: Schleicher County: Cave Y. Page 260 in W. R. Elliott and G. Veni, eds. The Caves and Karst of Texas. The National Speleological Society, Huntsville, Alabama.
- Elliott, W. R. and J. R. Reddell. 1994a. Texas Wild Caves: Val Verde County: Emerald Sink. Pages 284-285 in W. R. Elliott and G. Veni, eds. The Caves and Karst of Texas. The National Speleological Society, Huntsville, Alabama.
- Elliott, W. R. and J. R. Reddell. 1994b. Texas Wild Caves: Val Verde County: Four-Mile Cave (Sally Cave). Pages 289-292 in W. R. Elliott and G. Veni, eds. The Caves and Karst of Texas. The National Speleological Society, Huntsville, Alabama.
- Espinasa, L. and R. B. Borowsky. 2001. Origins and relationship of cave populations of the blind Mexican tetra, *Astyanax fasciatus*, in the Sierra de El Abra. Environmental Biology of Fishes 62:233-237.
- Folmer, O., M. Black, W. Hoeh, R. Lutz, and R. Vrijenhoek. 1994. DNA primers for amplification of mitochondrial cytochrome *c* oxidase subunit I from diverse metazoan invertebrates. Molecular Marine Biology and Biotechnology 3:294-299.
- Goldman, N., J. P. Anderson, and A. G. Rodrigo. 2000. Likelihood-based tests of topologies in phylogenetics. Systematic Biology 49:652-670.
- Hauwert, N. M., D. A. Johns, and J. M. Sharp. 2002. Evidence of discrete flow in the Barton Springs segment of the Edwards Aquifer. Pages 162-167 in J. B. Martin, C. M. Wicks, and I. D. Sasowsky, eds. Hydrogeology and Biology of Post-Paleozoic Carbonate Aquifers. Karst Waters Institute, Inc., Charles Town, West Virginia.

- Hendrickson, D. A. 1986. Congruence of bolitoglossine biogeography and phylogeny with geologic history: Paleotransport on displaced suspect terranes? *Cladistics* 3:113-129.
- Hendrickson, D. A., J. K. Krejca, and J. M. R. Martinez. 2001. Mexican Blindcats, genus *Prietella* (Siluriformes: Ictaluridae): an overview of recent explorations. *Environmental Biology of Fishes* 62:315-337.
- Hidding, B., E. Michel, A. V. Natyagoanova, and D. Yu. Sherbakov. 2003. Molecular evidence reveals a polyphyletic origin and chromosomal speciation of Lake Baikal's endemic asellid isopods. *Molecular Ecology* 12:1509-1514.
- Hillis, D. M., B. K. Mable, and C. Moritz. 1996. Applications of molecular systematics and the future of the field. Pages 515-543 *in* D. M. Hillis, B. K. Mable, and C. Moritz, eds. *Molecular Systematics*. Sinauer, Sunderland, MA.
- Huelsenbeck, J. P., D. M. Hillis, and R. Nielsen. 1996. A likelihood-ratio test of monophyly. *Systematic Biology* 45:546-558.
- Huelsenbeck, J. P. and F. Ronquist. 2001. MrBayes: Bayesian inference of phylogenetic trees. *Bioinformatics* 17:754-755.
- Johnson, S., G. M. Schindel, and G. Veni. 2005. Shavano Park/Sonterra research area (northern Bexar County). Pages 4-1-4-10 *in* G. M. Schindel, J. R. Hoyt, S. B. Johnson, G. Veni, B. P. Wilcox, C. L. Munster, S. D. Hovorka, C. W. Kreitler, and B. L. Shade, eds. *An Introduction to the Balcones Fault Zone Segment of the Edwards Aquifer in South-Central Texas*. National Groundwater Association and Edwards Aquifer Authority.
- Kane, T. C., D. C. Culver, and R. T. Jones. 1992. Genetic structure of morphologically differentiated populations of the amphipod *Gammarus minus*. *Evolution* 46:272-278.
- Ketmaier, V., R. Argano, M. Cobolli, E. De Matthaeis, and G. Messina. 1998. Cladogenetic events in two relict species of Stenasellidae

(Crustacea, Isopoda) from Sardinia Island (Tyrrhenian Sea): A biochemical approach. *Vie Et Milieu* 49:93-99.

- Kuniansky, E. L. and K. Q. Holligan. 1994. Simulations of flow in the Edwards-Trinity Aquifer System and contiguous hydraulically connected units, West-Central Texas. U.S. Geological Survey Water-Resources Investigations Report 93-4039:1-40.
- Lewis, J. J. The systematics, zoogeography, and life history of the troglobitic isopods of the Interior Plateaus of the eastern United States. 1-278. 1988. University of Louisville.
- Lewis, J. J. 2001. Three new species of subterranean asellids from western North America, with a synopsis of the species of the region (Crustacea: Isopoda: Asellidae). Pages 1-15 in J. R. Reddell and J. C. Cokendolpher, eds. Texas Memorial Museum, Speleological Monographs, 5. The University of Texas, Austin, Texas.
- Lewis, J. J. and T. E. Bowman. 1996. The subterranean asellids of Texas (Crustacea: Isopoda: Asellidae). *Proceedings of the Biological Society of Washington* 109:482-500.
- Leys, R., C. H. S. Watts, S. J. B. Cooper, and W. F. Humphreys. 2003. Evolution of subterranean diving beetles (Coleoptera: Dytiscidae: Hydroporini, Bidessini) in the arid zone of Australia. *Evolution* 57:2819-2834.
- Longley, G. 1981. The Edwards Aquifer: Earth's most diverse groundwater ecosystem? *International Journal of Speleology* 11:123-128.
- Mace, R. E., A. H. Chowdry, R. Anaya, and S.-C. T. Way. 2000. Groundwater Availability of the Trinity Aquifer, Hill Country Area, Texas: Numerical Simulations through 2050. Texas Water Development Board Report No. 353.
- Maclay, R. W. 1995. Geology and hydrology of the Edwards Aquifer in the San Antonio area, Texas. U.S. Geological Survey Water-Resources Investigations Report 95-4186:1-64.

- Maclay, R. W. and L. F. Land. 1988. Simulation of flow in the Edwards Aquifer, San Antonio region, Texas, and refinement of storage and flow concepts. U.S. Geological Survey Water-Supply Paper 2336-A:A1-A48.
- Mathieu, J., F. Jeannerod, F. Hervant, and T. C. Kane. 1997. Genetic differentiation of *Niphargus rhenorhodanensis* (Amphipoda) from interstitial and karst environments. *Aquatic Science* 59:39-47.
- Morrone, J. J. and J. V. Crisci. 1995. Historical Biogeography: Introduction to Methods. *Annual Review Ecological Systems* 26:373-401.
- Napper, G. 1994. Texas Wild Caves: Val Verde County: H. T. Miers Cave. Pages 292-296 in W. R. Elliott and G. Veni, eds. *The Caves and Karst of Texas*. The National Speleological Society, Huntsville, Alabama.
- Ogden, A. E., R. A. Quick, and S. A. Rothermel. 1986. Hydrochemistry of the Comal, Hueco, and San Marcos Springs, Edwards Aquifer, Texas. Pages 115-130 in P. L. Abbott and C. M. Woodruff, eds. *The Balcones Escarpment geology, hydrology, ecology and social development in central Texas*. Geological Society of America, San Antonio.
- Padgett, A. and B. Smith. 1987. *On Rope*. National Speleological Society, Huntsville, Alabama. Pages 1-341.
- Page, R. D. M. 1994. Parallel Phylogenies: Reconstructing the History of Host-Parasite Assemblages. *Cladistics* 10:155-173.
- Prosser, J. and H. V. Grey. 1992. *NSS Cave Diving Manual*. The Cave Diving Section of the National Speleological Society, Branford, Florida. Pages 1-377.
- Rambaut, A. and N. C. Grassly. 1997. Seq-Gen: An application for the Monte Carlo simulation of DNA sequence evolution along phylogenetic trees. *Comput. Appl. Biosci.* 13:235-238.

- Rea, T. 1987. Caving Basics. National Speleological Society, Huntsville, Alabama. Pages 1-128.
- Reddell, J. R. 1994. The cave fauna of Texas with special reference to the western Edwards Plateau. Pages 31-49 *in* W. R. Elliott and G. Veni, eds. The Caves and Karst of Texas. National Speleological Society, Huntsville, Alabama.
- Reddell, J. R., W. R. Elliott, M. Warton, and G. Veni. 1994. Texas Wild Caves: Crockett County: 0-9 Well. Pages 181-183 *in* W. R. Elliott and G. Veni, eds. The Caves and Karst of Texas. The National Speleological Society, Huntsville, Alabama.
- Rodriguez, J. M and Hendrickson, D. A. 1998. Estudio de los Bagres Ciegos en el Noreste de Mexico e Impacto de Contaminantes sobre los diferentes cuerpos de agua entre las ciudades de acuna y Piedras Negras, Coahuila.
- Rodriguez, J. M. and Berlanga, J. M. 1992. Posibilidades de contaminacion de tierras y aguas Mexicanas ante la apertura de los depositos de desechos radioactivos y toxicos peligrosos de Spofford y Dryden: perspectiva geohidrologica. 1-29.
- Russell, W. H. 1976. Distribution of troglobitic salamanders in the San Marcos area, Hays County, Texas. Biological Investigations of Troglobitic *Eurycea* Report, 7601, Pages 1-35.
- Schindel, G. M., J. R. Hoyt, S. Johnson, and C. W. Kreidler. 2005. Comal Springs and Landa Lake. Pages 6-1-6-21 *in* G. M. Schindel, J. R. Hoyt, S. Johnson, G. Veni, B. P. Wilcox, C. L. Munster, S. D. Hovorka, C. W. Kreidler, and B. L. Shade, eds. An Introduction to the Balcones Fault Zone Segment of the Edwards Aquifer in South-Central Texas. National Groundwater Association and Edwards Aquifer Authority.
- Seager, W. R., M. Shafiqullah, J. W. Hawley, and R. F. Marvin. 1984. New K-Ar dates from basalts and the evolution of the southern Rio Grande rift. Geological Society of America Bulletin 95:87-99.

- Sharp, J. M. 1998. Sustainable groundwater supplies - an evolving issue: examples from major carbonate aquifers of Texas, U.S.A. Pages 1-12 *in* T. R. Weaver and C. R. Lawrence, eds. *Groundwater: Sustainable Solutions*. International Association of Hydrologists, Melbourne.
- Sharp, J. M. and J. L. Banner. 1997. The Edwards Aquifer: A resource in conflict. *GSA Today* 7:1-9.
- Simon, C., F. Francesco, A. Beckenbach, C. Bernie, H. Liu, and P. Flook. 1994. Evolution, weighting, and phylogenetic utility of mitochondrial gene sequences and a compilation of conserved polymerase chain reaction primers. *Annals of the Entomological Society of America* 87:649-699.
- Stein, W. G. and G. B. Ozuna. 1996. Geologic framework and hydrogeologic characteristics of the Edwards Aquifer recharge zone, Bexar County, Texas. U.S. Geological Survey Water-Resources Investigations Report 95-4030:1-8.
- Swofford, D. L. PAUP\*. *Phylogenetic Analysis Using Parsimony (\*and Other Methods)*. Version 4. 2000. Sunderland, Massachusetts., Sinauer Associates.
- Swofford, D. L., G. J. Olsen, P. J. Waddell, and D. M. Hillis. 1996. *Phylogenetic Inference*. Pages 407-514 *in* D. M. Hillis, C. Moritz, and B. K. Mable, eds. *Molecular Systematics*. Sinauer Associates, Inc., Sunderland, Massachusetts.
- Thompson, J. D., T. J. Gibson, F. Plewniak, F. Jeanmougin, and D. G. Higgins. 1997. The ClustalX windows interface: flexible strategies for multiple sequence alignment aided by quality analysis tools. *Nucleic Acids Research* 24:4876-4882.
- Tucker, B. 2000. Phantom Lake Cave. *The Texas Caver* 45:4-7.
- Veni, G. 1994a. Hydrogeology and evolution of caves and karst in the southwestern Edwards Plateau, Texas. Pages 13-30 *in* W. R. Elliott



and G. Veni, eds. *The Caves and Karst of Texas*. National Speleological Society, Huntsville, Alabama.

- Veni, G. 1994b. Sorcerer's Cave. Pages 265-266 *in* W. R. Elliott and G. Veni, eds. *The Caves and Karst of Texas*. National Speleological Society, Huntsville, Alabama.
- Veni, G. 1994c. Texas Wild Caves: Comal County: Honey Creek Cave. Pages 175-178 *in* W. R. Elliott and G. Veni, eds. *The Caves and Karst of Texas*. The National Speleological Society, Huntsville, Alabama.
- Veni, G. 1994d. Texas Wild Caves: Edwards County: Devil's Sinkhole. Pages 193-197 *in* W. R. Elliott and G. Veni, eds. *The Caves and Karst of Texas*. The National Speleological Society, Huntsville, Alabama.
- Veni, G. 1994e. Texas Wild Caves: Medina County: Valdina Farms Sinkhole. Pages 236-238 *in* W. R. Elliott and G. Veni, eds. *The Caves and Karst of Texas*. The National Speleological Society, Huntsville, Alabama.
- Veni, G. 1994f. Texas Wild Caves: Terrell County: Sorcerer's Cave. Pages 265-266 *in* W. R. Elliott and G. Veni, eds. *The Caves and Karst of Texas*. The National Speleological Society, Huntsville, Alabama.
- Veni, G. 1997a. Evaluation of areas of potential influence on karst ecosystems for certain caves in Bexar County, Texas (part 2 of 2). *Prepared for*: U.S. Fish and Wildlife Service, Austin, Texas. George Veni and Associates, San Antonio, Texas. Pages 1-44.
- Veni, G. 1997b. Geomorphology, Hydrogeology, Geochemistry, and Evolution of the Karstic Lower Glen Rose Aquifer, South-Central Texas. The Pennsylvania State University, Texas Speleological Survey, Texas Speleological Monographs, 1. Pages 1-409.
- Veni, G., W. R. Elliott, R. S. Toomey III, and J. R. Reddell. 1996. Hydrogeologic and biological surveys of selected caves on Camp Bullis, Texas: Training areas 8,9,10, and 11. *Prepared for*: U.S.

Army Construction Engineering Research Laboratories, 2902  
Farber Drive, Champaign, IL 61821. George Veni and Associates,  
San Antonio, Texas. Pages 1-201.

Woodruff, C. M., Jr. and P. L. Abbott. 1986. Stream piracy and evolution of  
the Edwards Aquifer along the Balcones Escarpment, Central  
Texas. Pages 77-89 *in* P. L. Abbott and C. M. Woodruff, Jr., eds.  
The Balcones Escarpment: Geology, Hydrology, Ecology, and  
Social Development in Central Texas. Geological Society of  
America, San Antonio, Texas.

Woodruff, C. M. and P. L. Abbott. 1986. Stream Piracy and Evolution of  
the Edwards Aquifer Along the Balcones Escarpment, Central  
Texas. Pages 51-54 *in* P. L. Abbott and C. M. Woodruff, eds. The  
Balcones Escarpment geology, hydrology, ecology and social  
development in central Texas. Geological Society of America, San  
Antonio.

Worthington, S. R. H., D. C. Ford, and P. A. Beddows. 2000. Porosity and  
permeability enhancement in unconfined carbonate aquifers as a  
result of solution. Pages 463-471 *in* A. B. Klimchouck, D. C. Ford,  
A. N. Palmer, and W. Dreybrodt, eds. Speleogenesis: evolution of  
karst aquifers. National Speleological Society, Huntsville, Alabama.

## **Vita**

Jean Kathleen Krejca was born in Richmond, Indiana and grew up outside of Chicago, graduating from Saint Charles High School in 1990. From there she attended Southern Illinois University where she received a B.S. with honors in Zoology, a minor in Chemistry, and graduated magna cum laude. It was during her stay there that she took an interest in cave exploration, diving, and the problems studied by karst researchers. For two years of her undergraduate career she also worked for the Illinois Natural History Survey performing a bioinventory of the state's caves. After her graduation in 1995 she spent two years as an environmental consultant working in various Midwestern states on projects involving endangered bats, bobcats, and some game species. In 1997 she entered a Ph.D. program at the University of Texas at Austin where she combined her interests in biology and cave exploration to pursue a dissertation bridging cave biology and hydrogeology. Also during this time she worked for the United States Fish and Wildlife Service as a karst invertebrate specialist, and did some independent consulting related to endangered species problems in central Texas. In July of 2003, she and a business partner formed Zara Environmental LLC, an environmental consulting company, where she is currently employed.

Permanent address: 4806 Savorey Ln., Austin, TX 78744.

This dissertation was typed by the author.